

DL9219 溫濕度計時鐘

一) 功能特性

- 1) 工作電壓1.5V, 超低電源功耗
- 2) 基本的時間顯示, 有12/24小時轉換
- 3) 年曆範圍: 2000~2099年. (開機顯示2005年)
- 4) 可選擇攝氏或華氏顯示溫度
- 5) 溫度範圍:
 - 室外: $-50 \sim +70 \text{ degC}$ ($-58 \sim 158 \text{ degF}$)
 - 室內: $-10 \sim +60 \text{ degC}$ ($14 \sim +140 \text{ degF}$)
 - 溫度精確度: $\pm 1 \text{ degC}$
 - 溫度顯示精度: 0.1 degC
- 6) 濕度顯示範圍: 20~90%RH
- 濕度精確度: $\pm 5\%RH$
- 7) 有鬧鐘顯示和5分鐘貪睡功能
- 8) 有按鍵提示音

二) 液晶顯示圖案

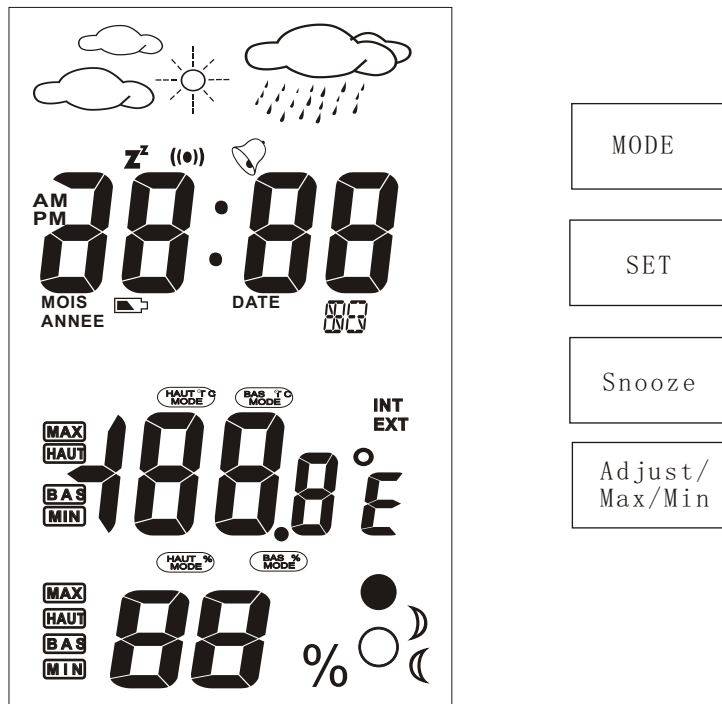

DL9219

三) 流程圖

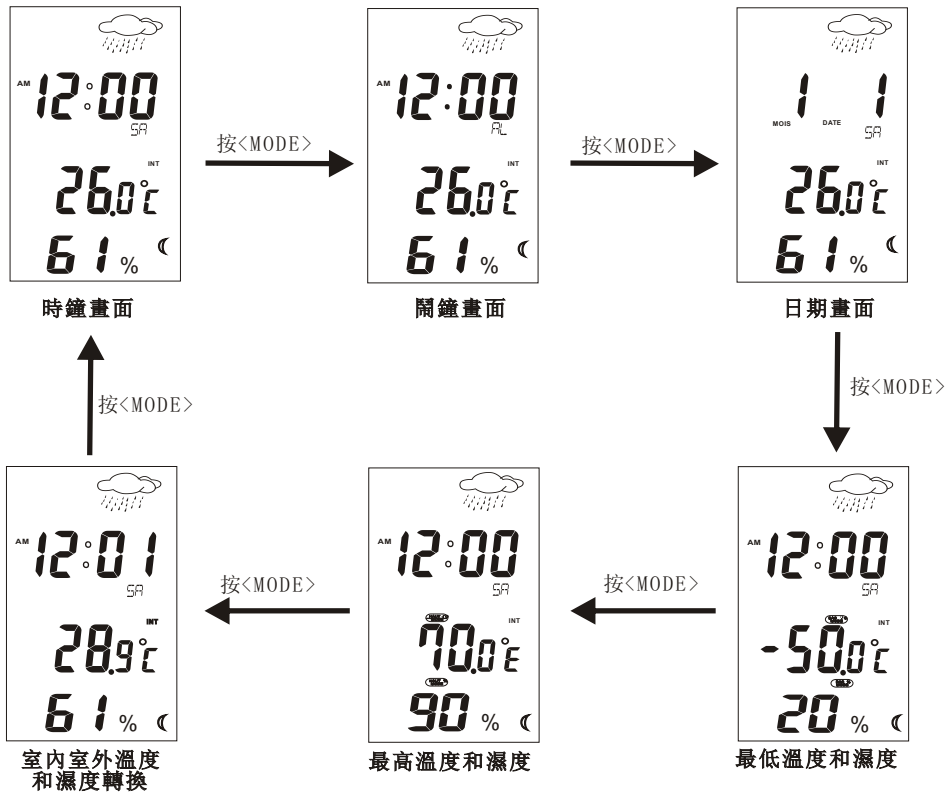

四) 操作說明

1) 設定時間

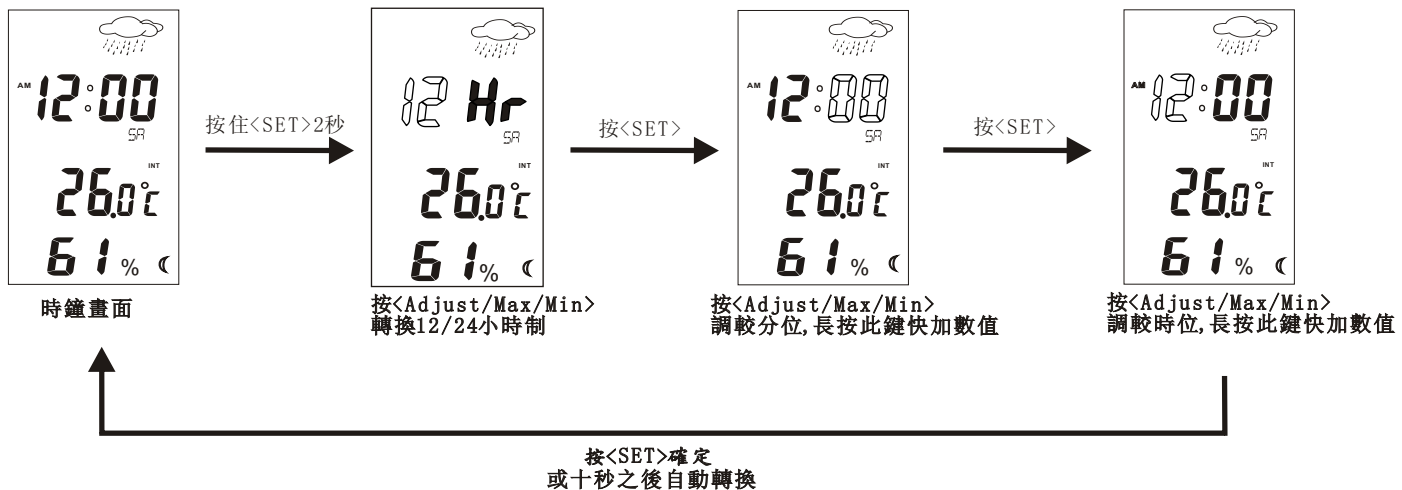

5) 設定最高溫濕度警報

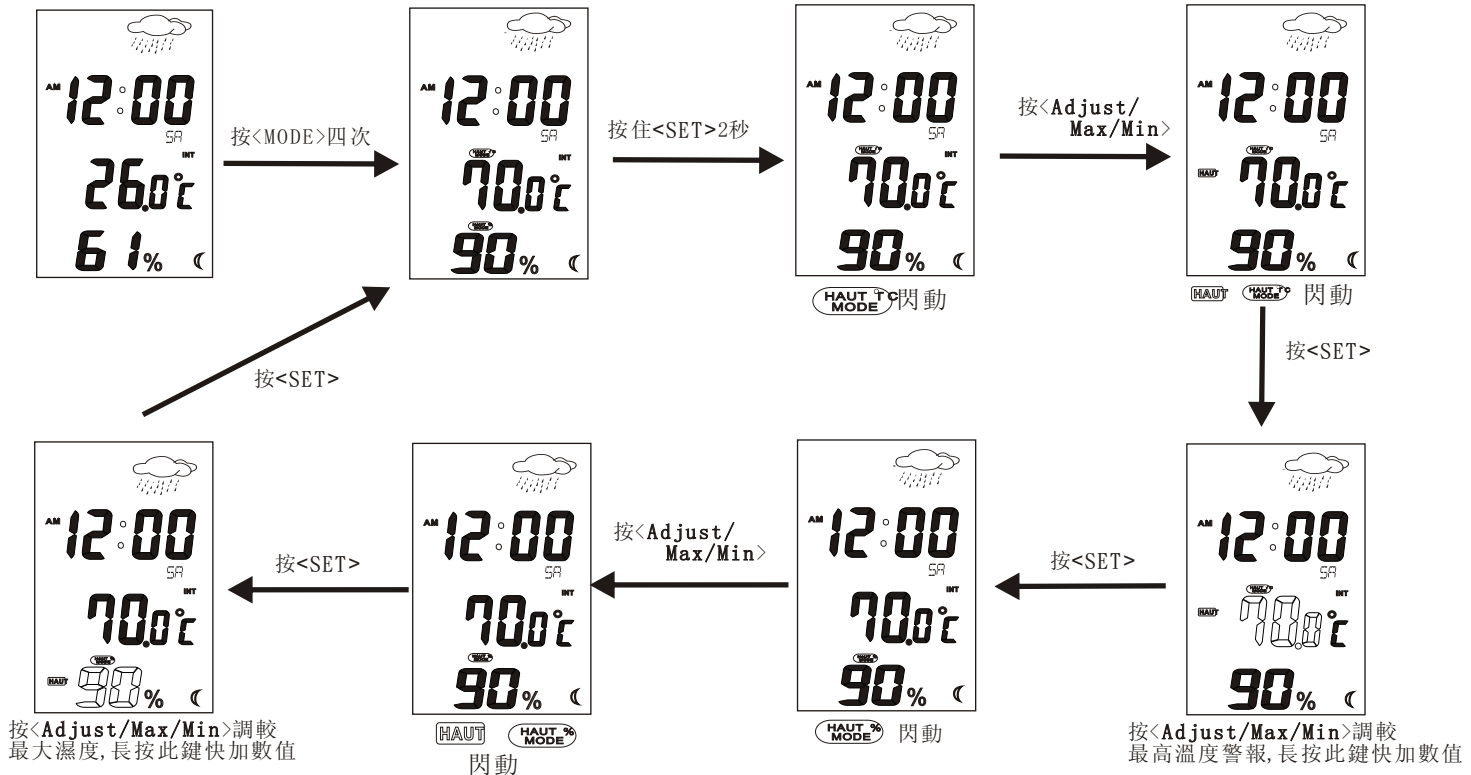

關閉最高溫濕度警報

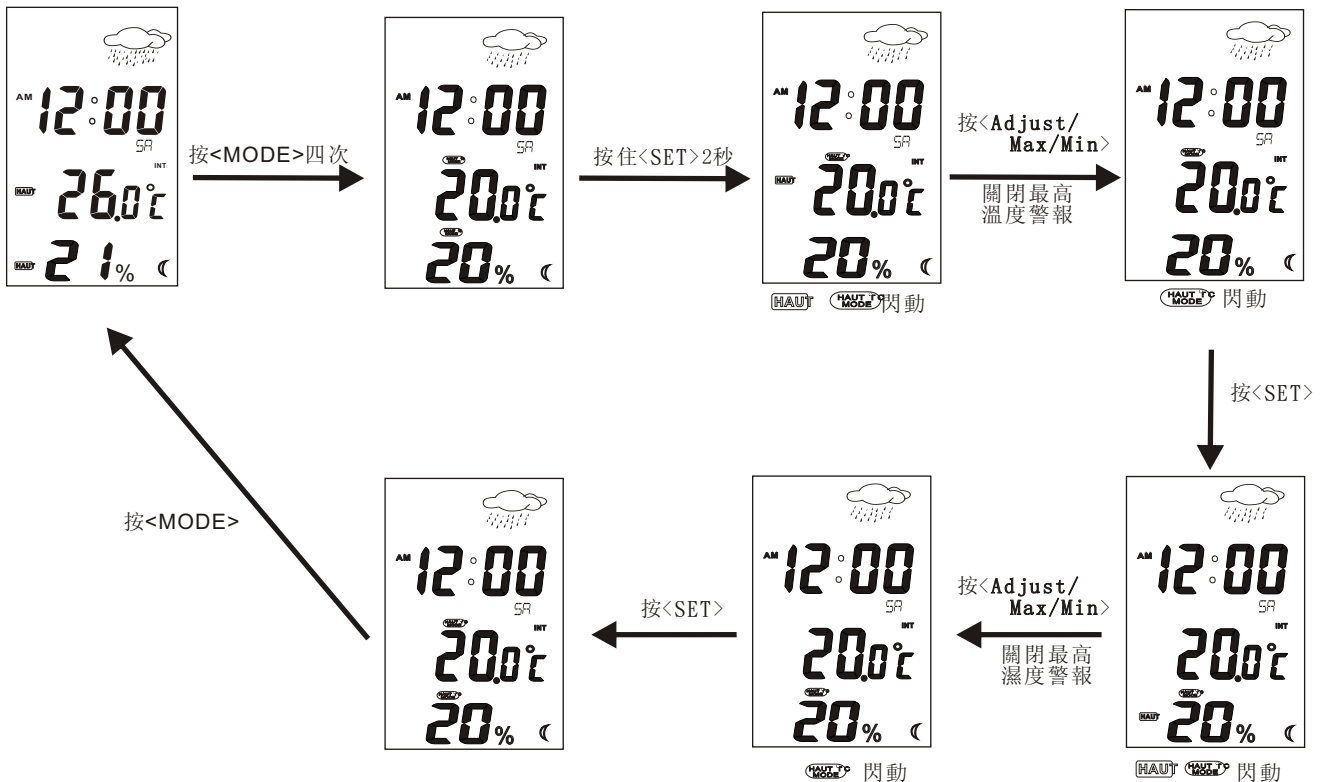

註:溫濕度警報響5秒.

6) 轉換室內外溫濕度顯示

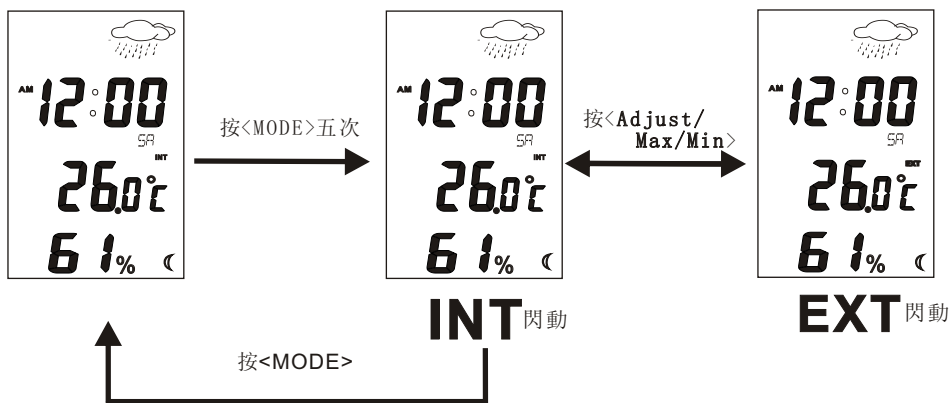

註: 於室內外顯示畫面按 <Adjust/Max/Min>2秒，最大和最小溫濕度記憶會被清除，最大和最小溫濕度值隨即被設為現當的溫濕度數值。

7) 天氣動畫

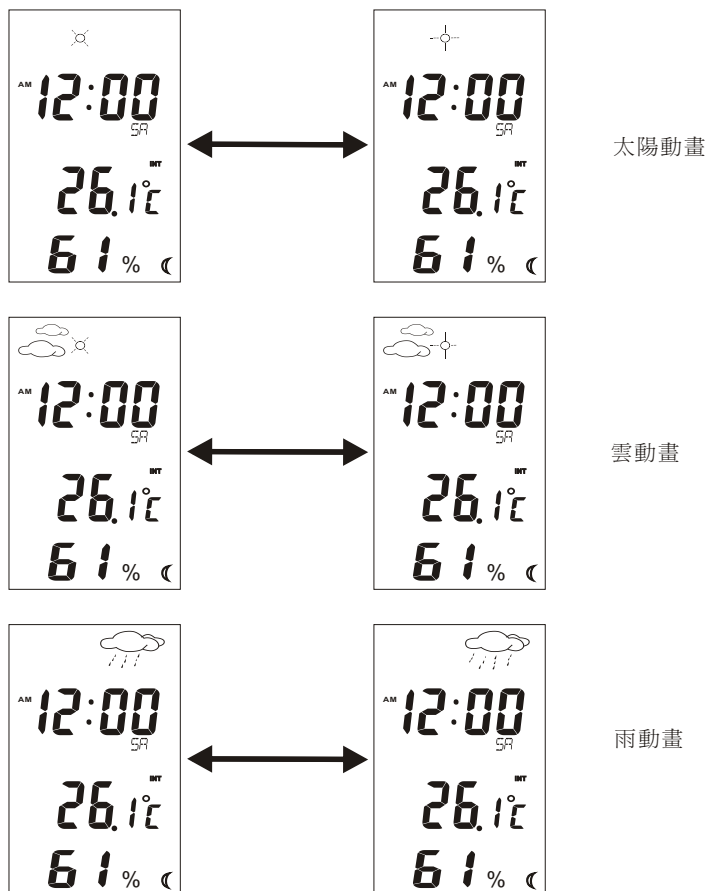

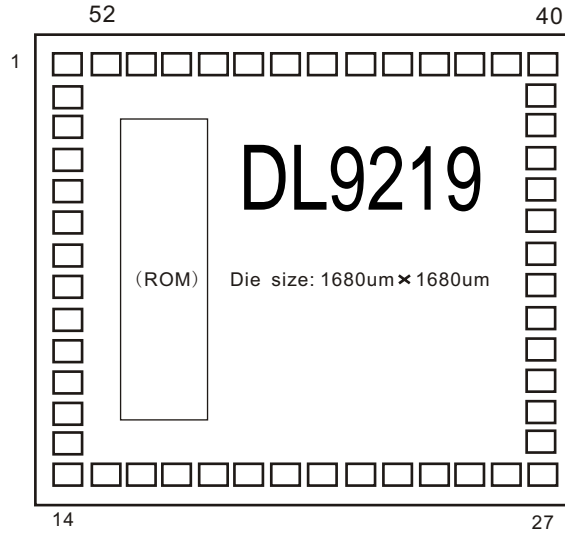

The substrate of chip should be corrected to GND.

NO	NAME	X	Y	NO	NAME	X	Y
1	N.C.	77.5	1602.5	27	SEG13	1602.5	77.5
2	XIN	77.5	1472.5	28	SEG14	1602.5	207.5
3	XOUT	77.5	1357.5	29	SEG15	1602.5	322.5
4	GND	77.5	1242.5	30	SEG16	1602.5	437.5
5	VDD1	77.5	1127.5	31	SEG17	1602.5	552.5
6	VDD2	77.5	1012.5	32	SEG18	1602.5	667.5
7	VDD3	77.5	897.5	33	SEG19	1602.5	782.5
8	CUP1	77.5	782.5	34	SEG20	1602.5	897.5
9	CUP2	77.5	667.5	35	SEG21	1602.5	1012.5
10	COM1	77.5	552.5	36	SEG22	1602.5	1127.5
11	COM2	77.5	437.5	37	SEG23	1602.5	1242.5
12	COM3	77.5	322.5	38	CX	1602.5	1357.5
13	COM4	77.5	207.5	39	RR	1602.5	1472.5
14	COM5	77.5	77.5	40	RT	1602.5	1602.5
15	SEG1	207.5	77.5	41	SEG27	1472.5	1602.5
16	SEG2	322.5	77.5	42	IOB1	1372.5	1602.5
17	SEG3	437.5	77.5	43	IOB2	1242.5	1602.5
18	SEG4	552.5	77.5	44	IOB3	1127.5	1602.5
19	SEG5	667.5	77.5	45	BZ	1012.5	1602.5
20	SEG6	782.5	77.5	46	IOC1	897.5	1602.5
21	SEG7	897.5	77.5	47	IOC2	782.5	1602.5
22	SEG8	1012.5	77.5	48	IOC3	667.5	1602.5
23	SEG9	1127.5	77.5	49	IOC4	552.5	1602.5
24	SEG10	1242.5	77.5	50	RESET	437.5	1602.5
25	SEG11	1357.5	77.5	51	INT	322.5	1602.5
26	SEG12	1472.5	77.5	52	N.C.	207.5	1602.5

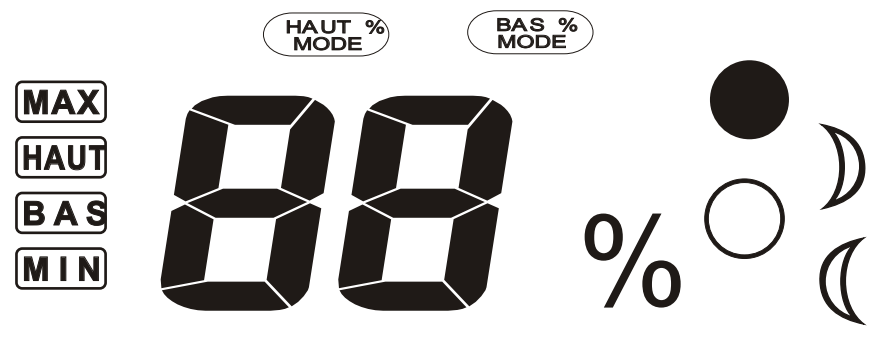
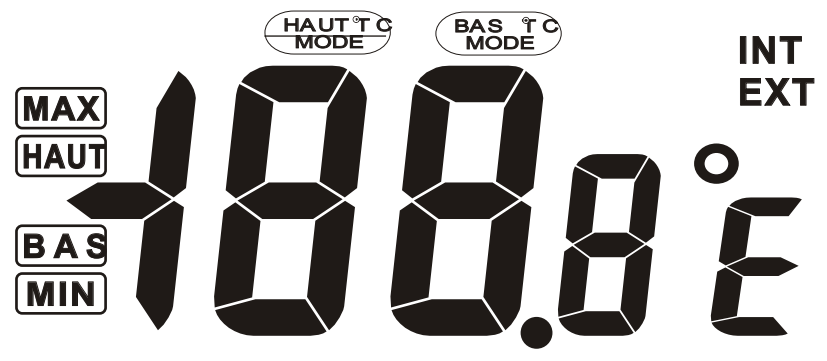
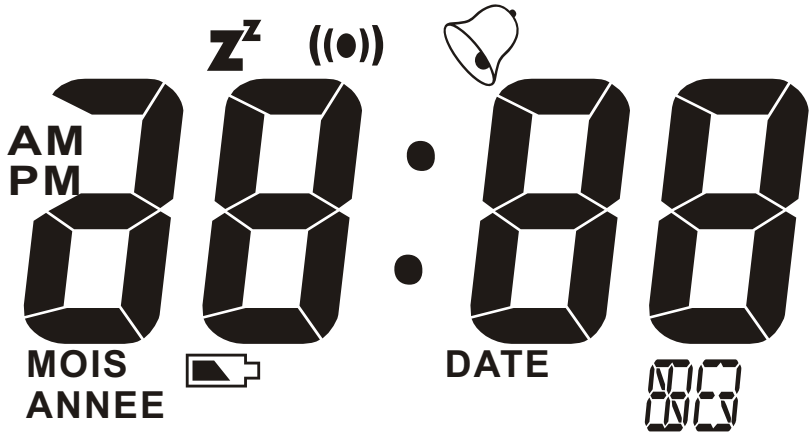
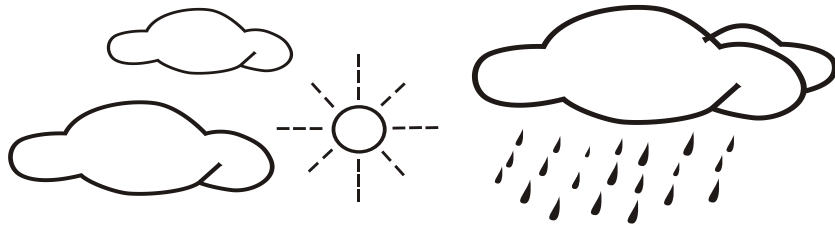

1/5 Duty, 1/3 Bias, Vlcd 4.5V

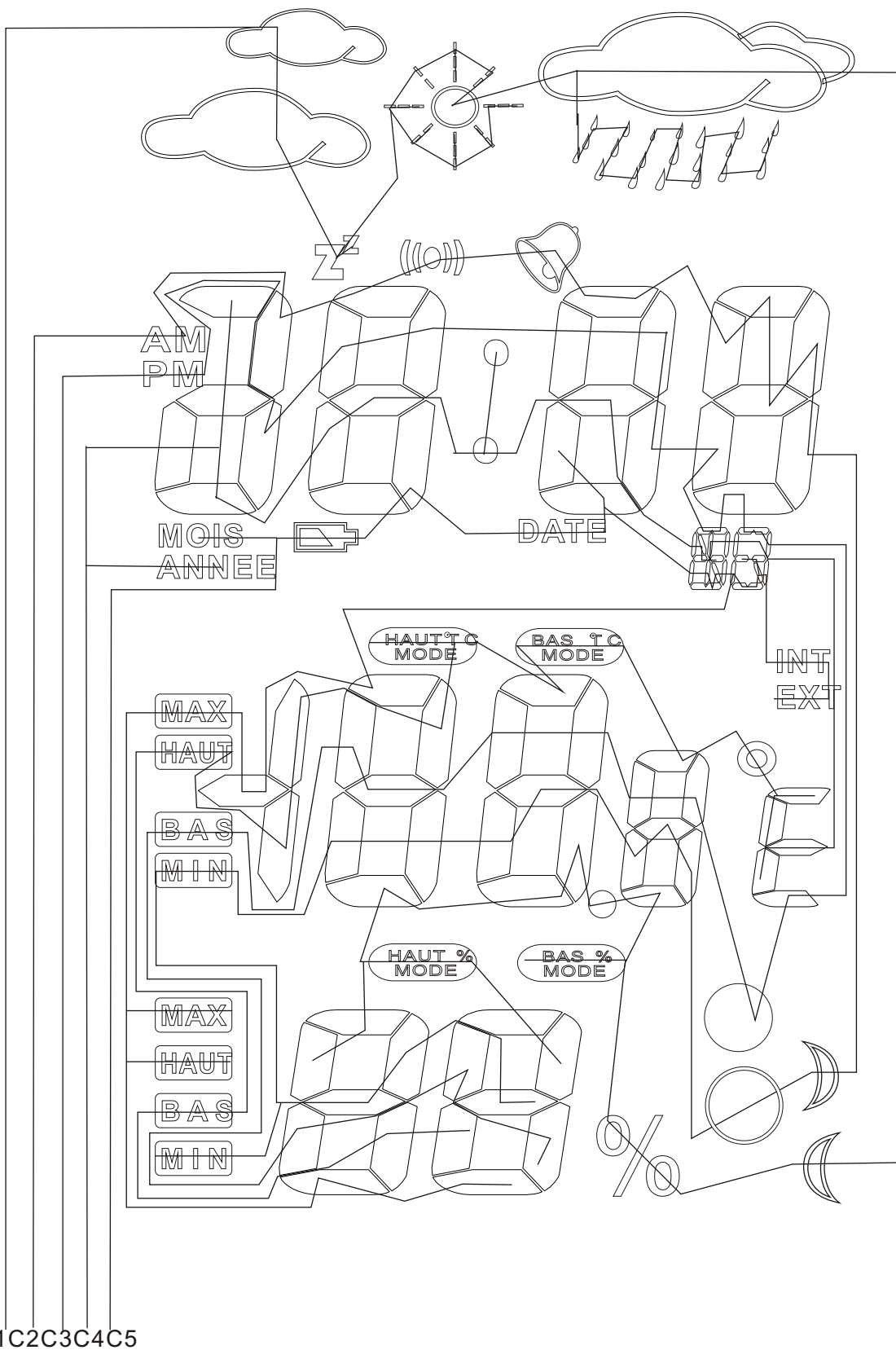

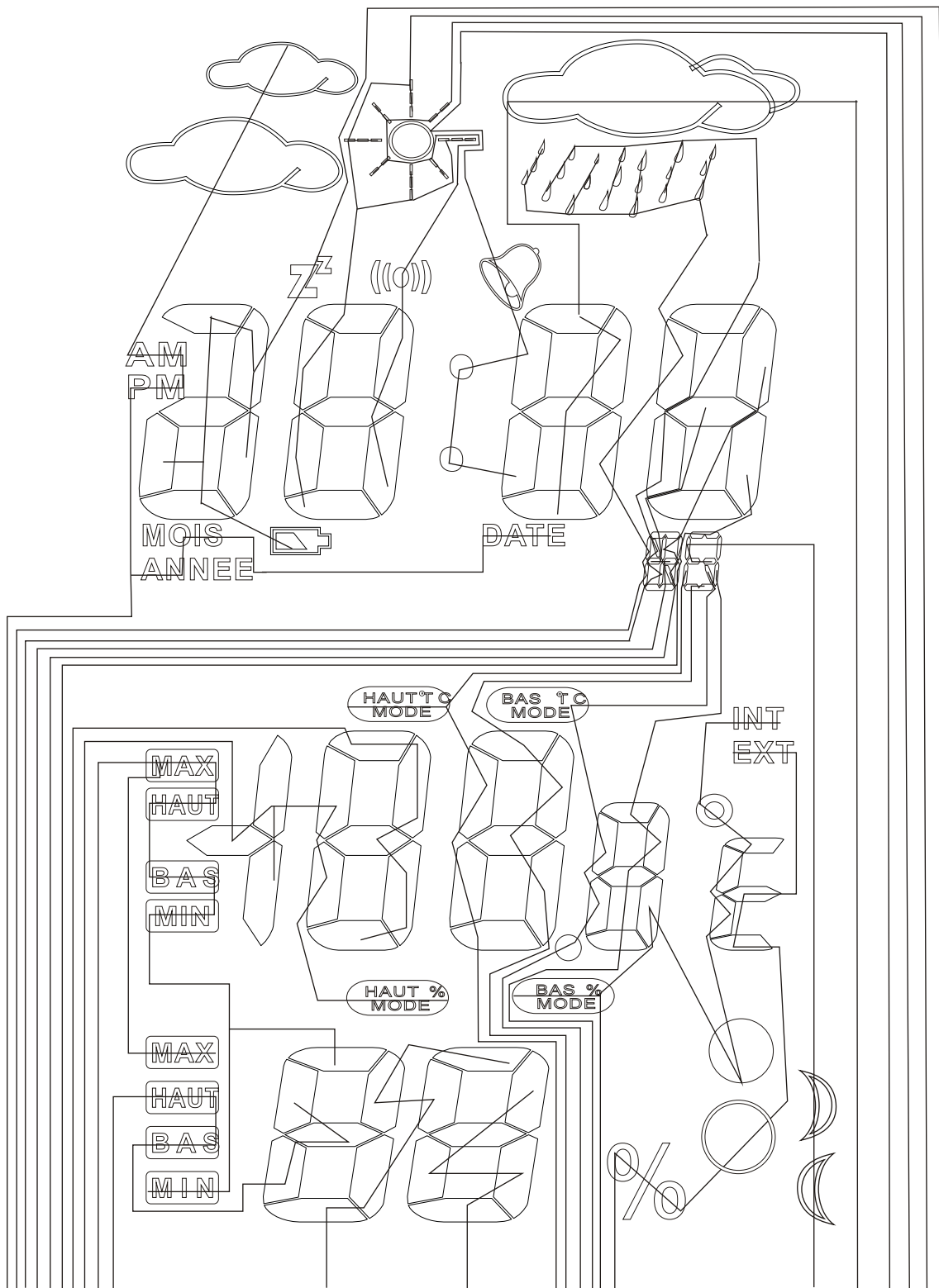

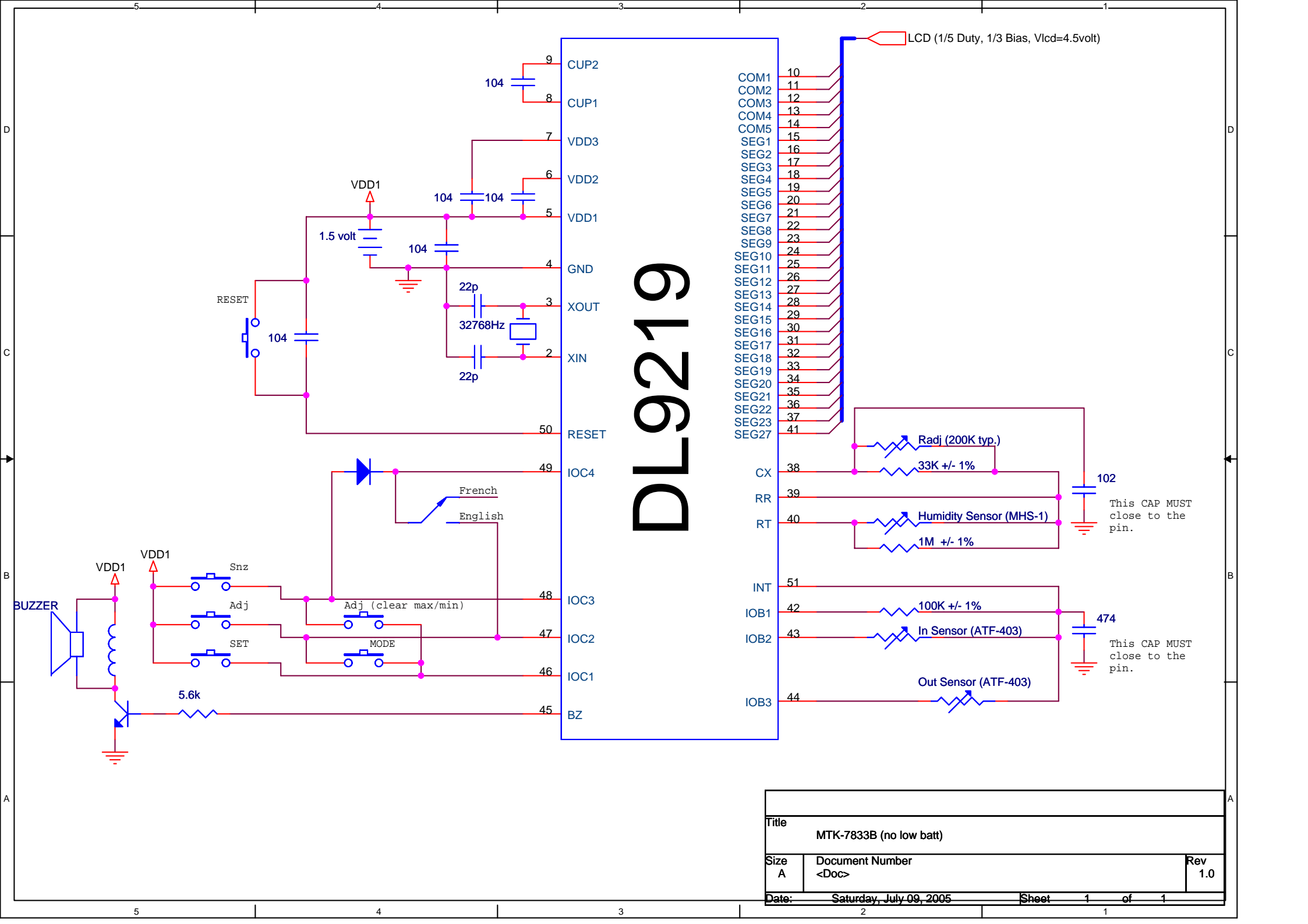

DL9219

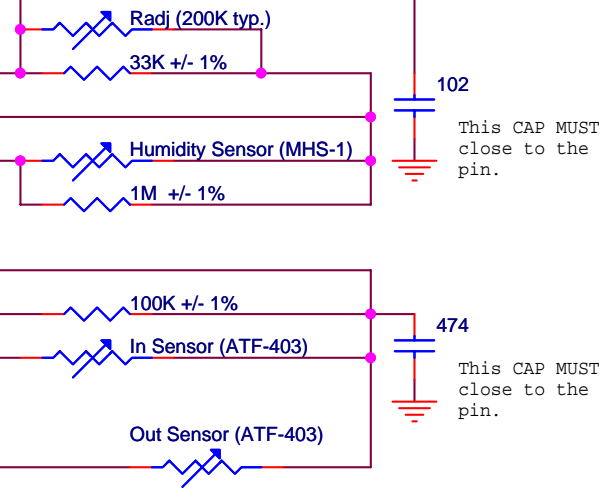
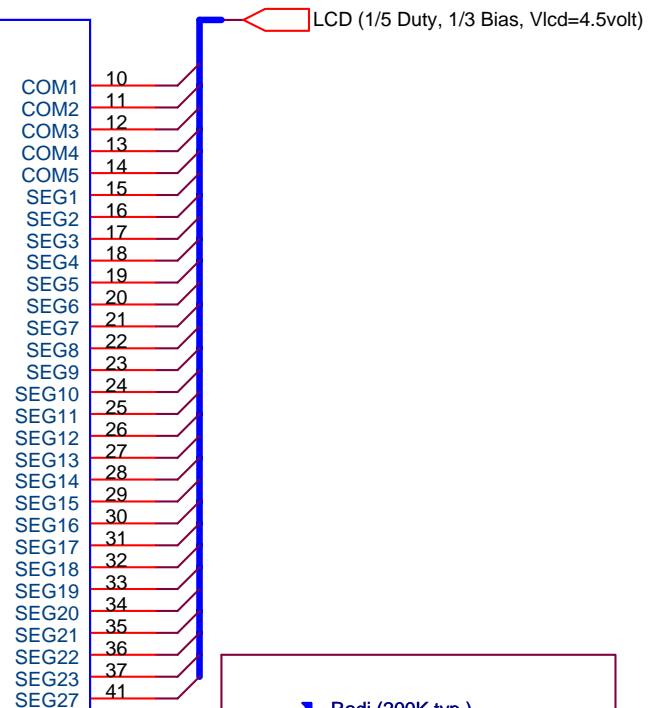

Title		
MTK-7833B (no low batt)		
Size	Document Number	Rev
A	<Doc>	1.0
Date:	Saturday, July 09, 2005	Sheet 1 of 1