



DL8835

LED Driver IC

DESCRIPTION

DL8835 is an LED Controller driven on a 1/4 to 1/7 duty factor. Twelve/nine segment output lines, 4 to 7 grid output lines, one display memory, control circuit are all incorporated into a single chip to build a highly reliable peripheral device for a single chip microcomputer. Serial data is fed to DL8835 via a three-line serial interface. Housed in a 24-pin SO Package, DL8835's pin assignments and application circuit are optimized for easy PCB Layout and cost saving advantages.

FEATURES

- CMOS Technology
- Low Power Consumption
- 8-Step Dimming Circuitry
- Serial Interface for Clock, Data Input, Strobe Pins
- Available in 24-pin, SO Package

APPLICATION

- Micro-computer Peripheral Device

BLOCK DIAGRAM

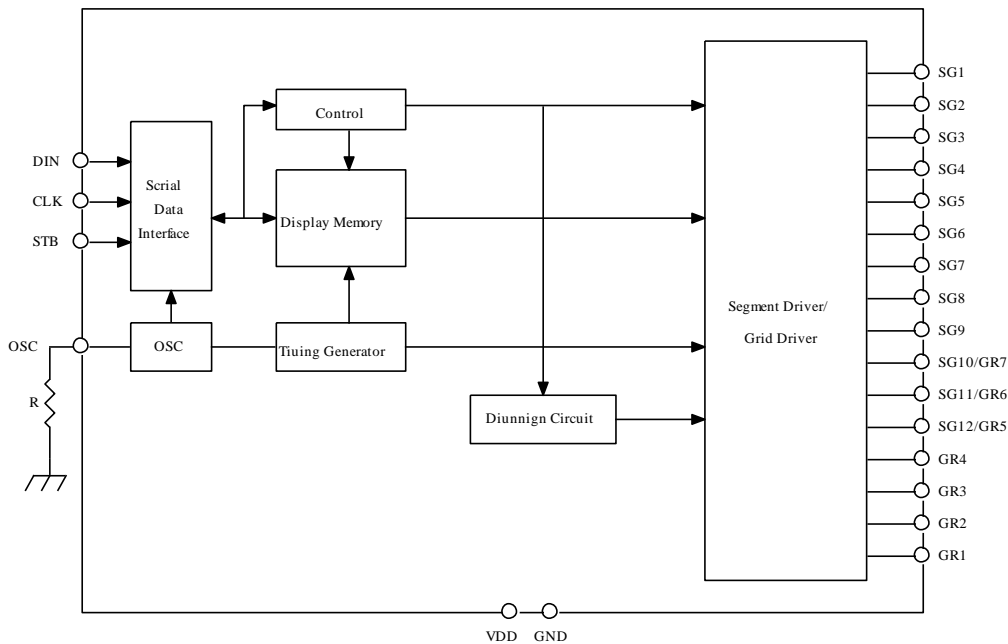

PIN CONFIGURATION

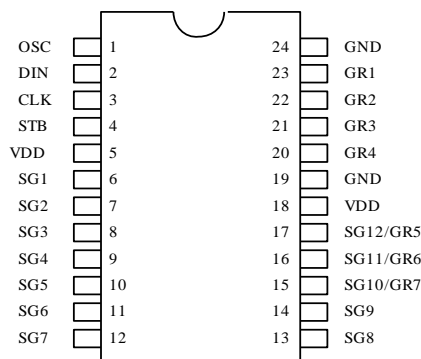



DL8835

LED Driver IC

INPUT / OUTPUT CONFIGURATIONS

The Schematic diagrams of the input and output circuits of the logic section are shown below.

Input Pins: CLK, STB & DIN

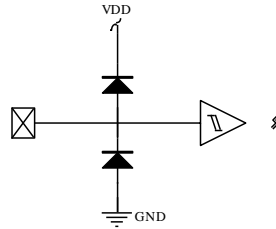

Output Pins: SG10/GR7, SG11/GR6, SG12/GR5

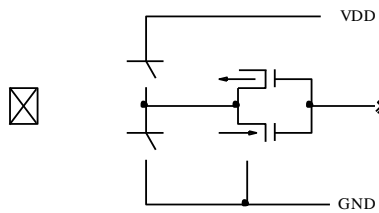

Output Pins: GR1 to GR4

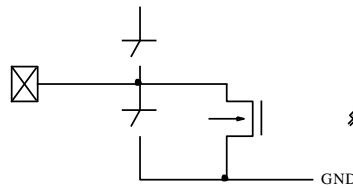

Output Pins: SG1 to SG9

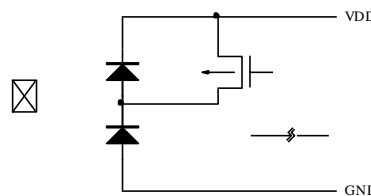

PIN DESCRIPTION

Pin Name	I/O	DeScription	Pin NO.
OSG	I	OSGillator Input Pin A resistor is connected to this pinto determine the oSGillation frequency	1
DIN	I	Data Input Pin This pin inputs serial data at the rising edge of the shift clock (starting from the lower bit)	2
CLK	I	Clock Input Pin This pin reads serial data at the rising edge.	3
STB	I	Serial Interface Strobe Pin The data input after the STB has fallen is processed as a command. When this pin is " HIGH ", CLK is ignored.	4
VDD	-	Power Supply	5,18
SG1 to SG9	O	Segment Output Pins (p-channel, open drain)	6~14
SG10/GR7 to SG12/GR5	O	Segment Output Pin/Grid Output Pin (CMOS Output)	15~17
GND	-	Ground Pin	19,24
GR4 to GR1	O	Grid Output Pins (n-channel, open drain)	20~23



DL8835

LED Driver IC

FUNCTIONAL DESCRIPTION

Commands

A command is the first byte (b0 to b7) inputted to DL8835 via the DIN Pin after STB Pin has changed from "HIGH" to "LOW" State. If for some reason the STB Pin is set to "HIGH" while data or commands are being transmitted, the serial communication is initialized, and the data/commands being transmitted are considered invalid.

COMMAND 1: DISPLAY MODE SETTING COMMANDS

DL8835 provides 4 display mode settings as shown in the diagram below: As stated earlier a command is the first one byte (b0 to b7) transmitted to DL8835 via the DIN Pin when STB is "LOW". However, for these commands, Bit No. 3 to Bit No.6 (b2 to b5) are ignored, Bit No. 7 & Bit No. 8 (b6 to b7) are given a value of "0".

The Display Mode Setting Commands determine the number of segments and grids to be used (1/4 to 1/7 duty, 12 to 9 segments). When these commands are executed, the display is forcibly turned off. A display command "ON" must be executed in order to resume display. If the same mode setting is selected, no command execution is take place, therefore, nothing happens.

When Power is turned "ON", the 7-Grid , 9-Segment Mode is selected.

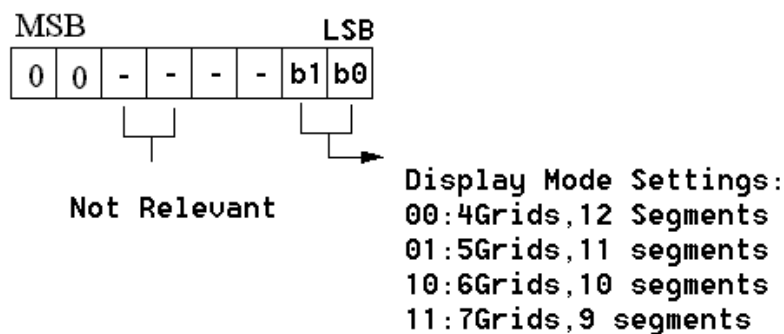

COMMAND 2: DATA SETTING COMMANDS

The Data Setting Commands executes the Data Write Mode for DL8835. The Data Setting Command, the bits 5 and 6 (b4, b5) are ignored, bit 7 (b6) is given the value of "1" while bit 8 (b7) is given the value of "0". Please refer to the diagram below.

When power is turned ON, bit 4 to bit 1 (b3 to b0) are given the value of "0".

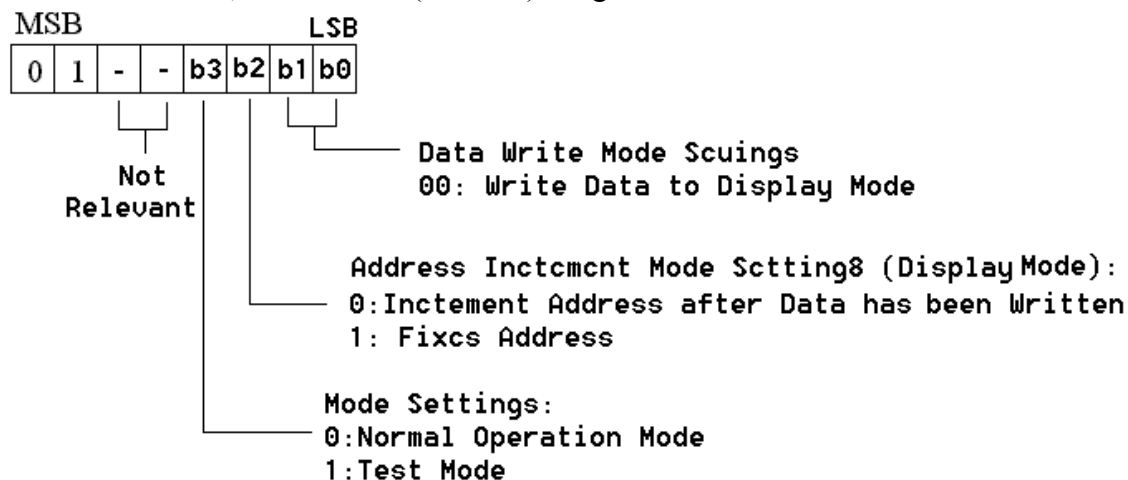

COMMAND 3: ADDRESS SETTING COMMANDS

Address Setting Commands are used to set the address of the display memory. The address is



DL8835

LED Driver IC

considered valid if it has a value of “00H” to 0DH”. If the address is set to 0EH or higher, the data is ignored until a valid address is set. When power is turned ON, the address is set at “00H”.

Please refer to the diagram below.

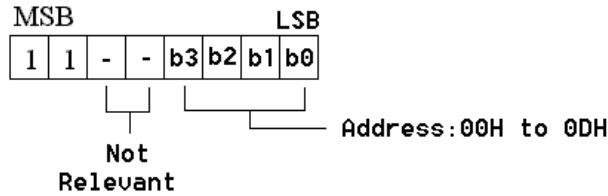

Display Mode and RAM Address

Data transmitted from an external device to DL8835 via the serial interface are stored in the Display RAM and are assigned addresses. The RAM Addresses of DL8835 are given below in 8 bits unit.

SG1	SG4	SG5	SG8	SG9	SG12	
00HL	00HU	01HL				DIG1
02HL	02HU	03HL				DIG2
04HL	04HU	05HL				DIG3
06HL	06HU	07HL				DIG4
08HL	08HU	09HL				DIG5
0AHL	0AHU	0BHL				DIG6
0CHL	0CHU	0DHL				DIG7

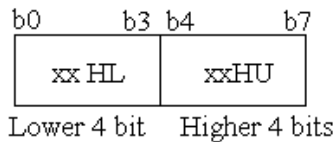

COMMAND 4: DISPLAY CONTROL COMMANDS

The Display Control Commands are used to turn ON or OFF a display. It also used to set the pulse width. Please refer to the diagram below. When the power is turned ON, a 1/16 pulse width is selected and the displayed is turned OFF.

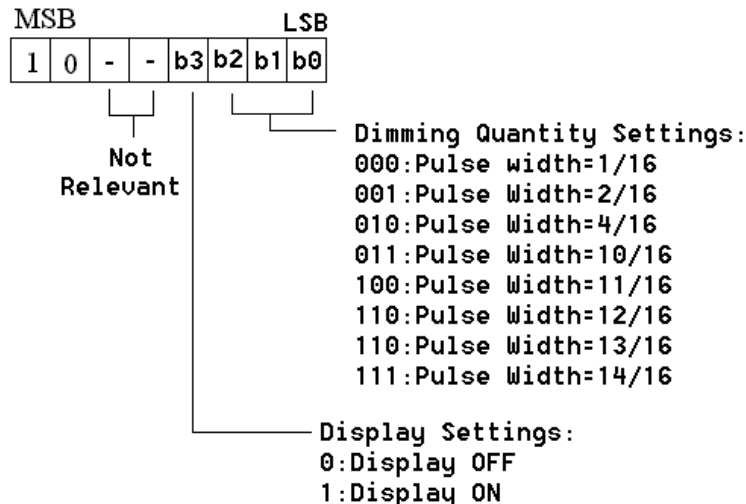



DL8835

LED Driver IC

DISPLAY TIMING WAVEFORM

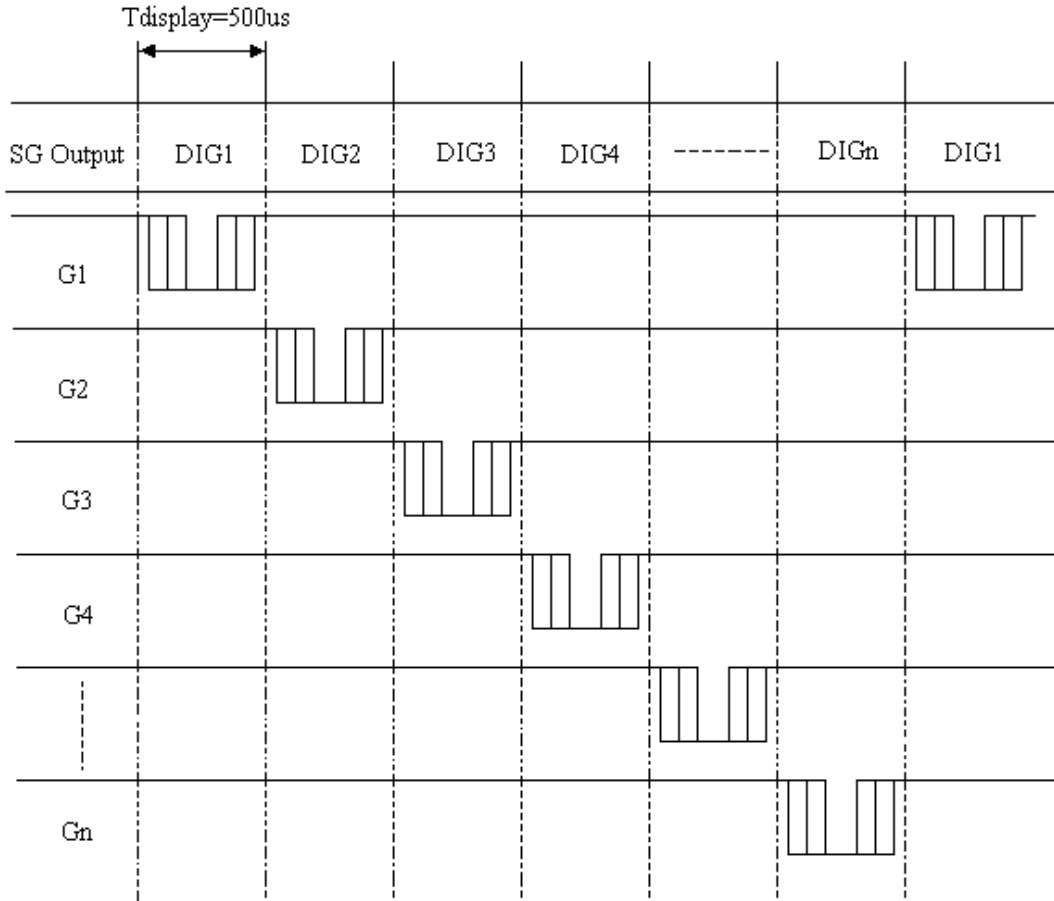

SERIAL COMMUNICATION FORMAT

The following diagram shows the DL8835 serial communication format.

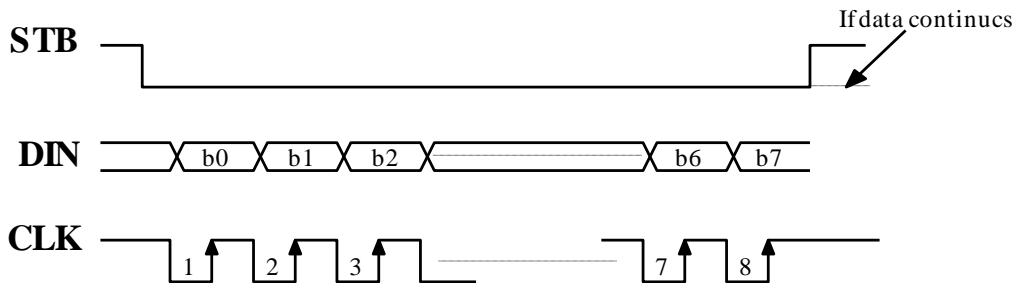



DL8835

LED Driver IC

SWITCHING CHARACTERISTIC WAVEFORM

DL8835 Switching Characteristics Waveform is given below.

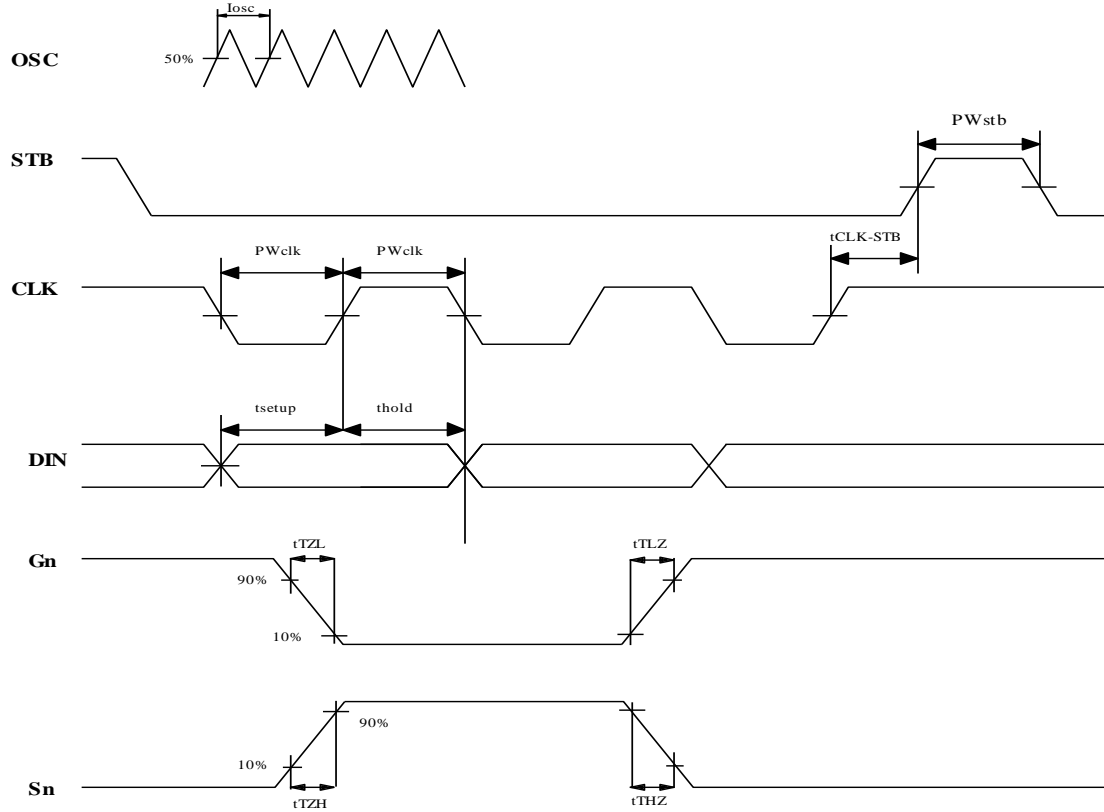

where: PW_{CLK} (Clock Pulse Width) $\geq 400ns$
 t_{setup} (Data Setup Time) $\geq 100ns$
 $t_{CLK-STB}$ (Clock-Strobe Time) $\geq 1\mu s$
 t_{TZH} (Rise Time) $\leq 1\mu s$
 $t_{TZL} < 1\mu s$

PW_{STB} (Strobe Pulse Width) $\geq 1\mu s$
 t_{hold} (Data Hold Time) $\geq 100ns$
 t_{THZ} (fall Time) $\leq 10\mu s$
 f_{oSG} = OSGillation Frequency
 $t_{TLZ} < 10\mu s$

APPLICATIONS

Display memory is updated by is incrementing addresses. Please refer to the following diagram.

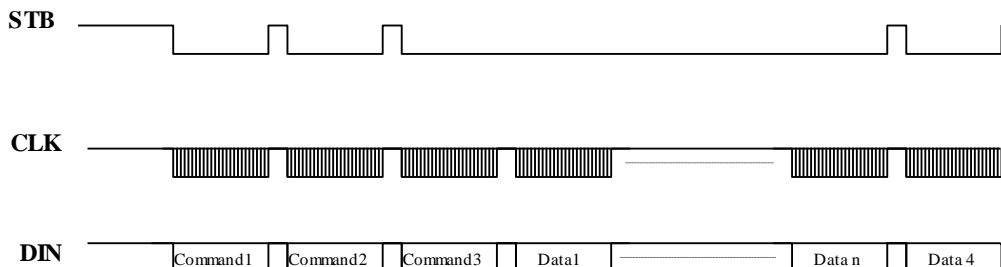

where: Command 1: Display Mode Setting
 Command 2: Data Setting Command
 Command 3: Address Setting Command
 Data 1 to n : Transfer Display Data (14 Bytes max.)
 Command 4: Display Control Command

The following diagram shows the waveforms when updating specific addresses.



DL8835

LED Driver IC

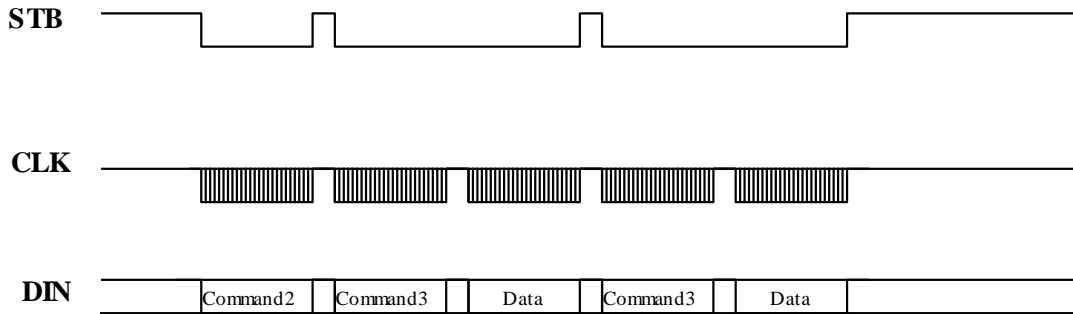

Where: Command2-- Data Setting Command

Command3-- Address Setting Command

Data--Display Data

RECOMMENDED SOFTWARE PROGRAMMING FLOWCHART

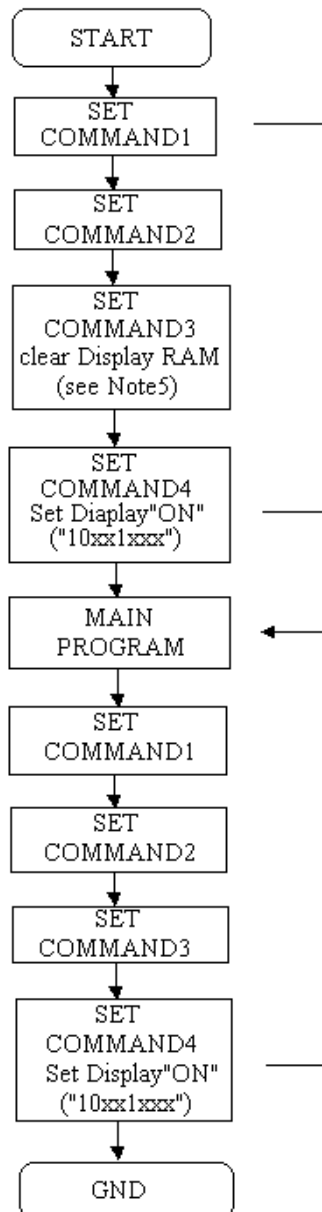

Note: 1. Command 1: Display Mode Setting Commands

2. Command 2: Data Setting Commands



DL8835

LED Driver IC

3. Command 3 : Address Setting Commands

4. Command 4: Display Control Commands

5. When IC power is applied for the first time, the contents of the Display RAM are not defined; thus, it is strongly suggested that the contents of the Display RAM must be cleared during the initial setting.

SOP 24L (300MIL) THERMAL PERFORMANCE IN STILL AIR

Junction Temperature: 100 °C

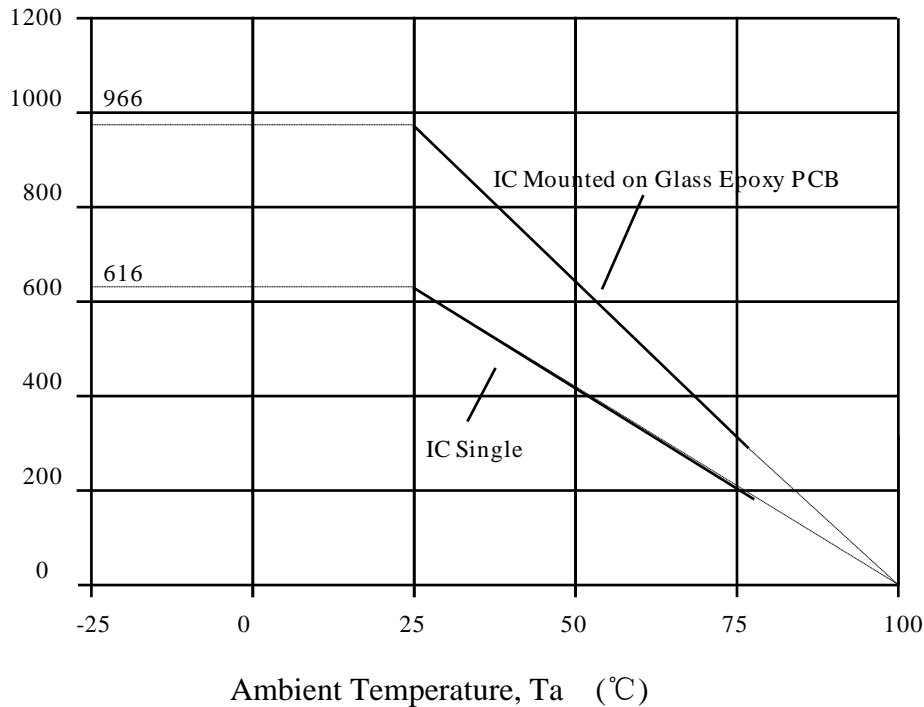

ABSOLUTE MAXIMUM RATINGS

(Unless otherwise stated, Ta=25°C, GND=0V)

Parameter	Symbol	Rating	Units
Supply Voltage	V _{DD}	-5.0 to +7.0	Volt
Logic Input Voltage	V _I	-0.5 to V _{DD} +0.5	Volts
Driver Output Current/Pin	I _{OLGR}	+250	mA
	I _{OHS}	-50	mA
Maximum Driver Output Current/Total	I _{TOTAL}	400	mA

RECOMMENDED OPERATING RANGE

(Unless otherwise stated, Ta=-20 to +70°C, GND=0V)

Parameter	Symbol	Min.	Typ.	Max.	Unit
Logic Supply Voltage	V _{DD}	4.5	5	5.5	V
Dynamic Current (see Note)	I _{DDdyn}	-	-	5	mA
High-Level Input Voltage	V _{IH}	0.8V _{DD}	-	V _{DD}	V
Low-Level Input Voltage	V _{IL}	0	-	0.3V _{DD}	V

Note: Test Condition: Set Display Control Commands = 80H (Display Turn OFF State)

ELECTRICAL CHARACTERISTICS

(Unless otherwise stated, V_{DD}=5V, GND=0V, Ta=25°C)

Parameter	Symbol	Test Condition	Min.	Typ.	Max.	Unit
-----------	--------	----------------	------	------	------	------



DL8835

LED Driver IC

High-Level Output Current	$I_{OHSG(1)}$	$V_o = V_{DD} - 1V$ SG1 to SG9, SG10/GR7 to SG12/GR5	-10	-14	-30	mA
	$I_{OHSG(2)}$	$V_o = V_{DD} - 2V$ SG1 to SG9, SG10/GR7 to SG12/GR5	-20	-25	-50	mA
Low-Level Output Current	I_{OLGR}	$V_o = 0.3V$ GR1 to GR4, SG10/GR7 to SG12/GR5	100	140	-	mA
Segment High-Level Output Current Tolerance	I_{TOLSG}	$V_o = V_{DD} - 1V$ SG1 to SG9 SG10/GR7 to SG12/GR5	-	-	± 5	%
High- Level Input Voltage	V_{IH}	-	$0.8V_{DD}$	-	-	V
Low- Level Input Voltage	V_{IL}	-	-	-	$0.3 V_{DD}$	V
OSGillation Frequency	foSG	R=51 Kohms	350	500	650	KHz

PAD

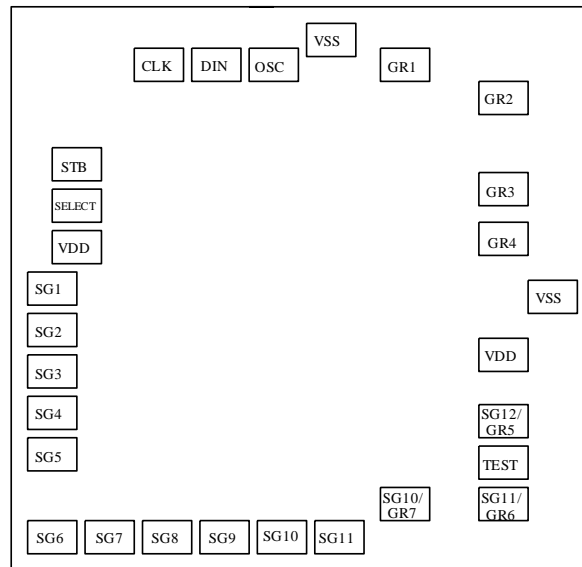

No	PAD	X	Y	No	PAD	X	Y
1	STB	103.7	1064	15	SG10/GR7	737	136.5
2	SELECT	103.7	946.8	16	SG11/GR6	956	136.5



DL8835

LED Driver IC

3	VDD	103.7	836.8	17	TEST	969.2	288.5
4	SG1	46.5	724.3	18	SG12/GR5	956	375.5
5	SG2	46.5	614.3	19	VDD	956	498.4
6	SG3	46.5	504.3	20	VSS	1069.6	608.4
7	SG4	46.5	394.3	21	GR4	956	779.6
8	SG5	46.5	284.3	22	GR3	956	974.4
9	SG6	48.8	51.5	23	GR2	956	1191
10	SG7	158.8	51.5	24	GR1	766.8	1226
11	SG8	268.8	51.5	25	VSS	619.8	1349.6
12	SG9	378.8	51.5	26	OSG	504.4	1256.3
13	SG10	488.8	51.5	27	DIN	386.9	1256.3
14	SG11	598.8	51.5	28	CLK	264	1256.3

APPLICATION CIRCUIT

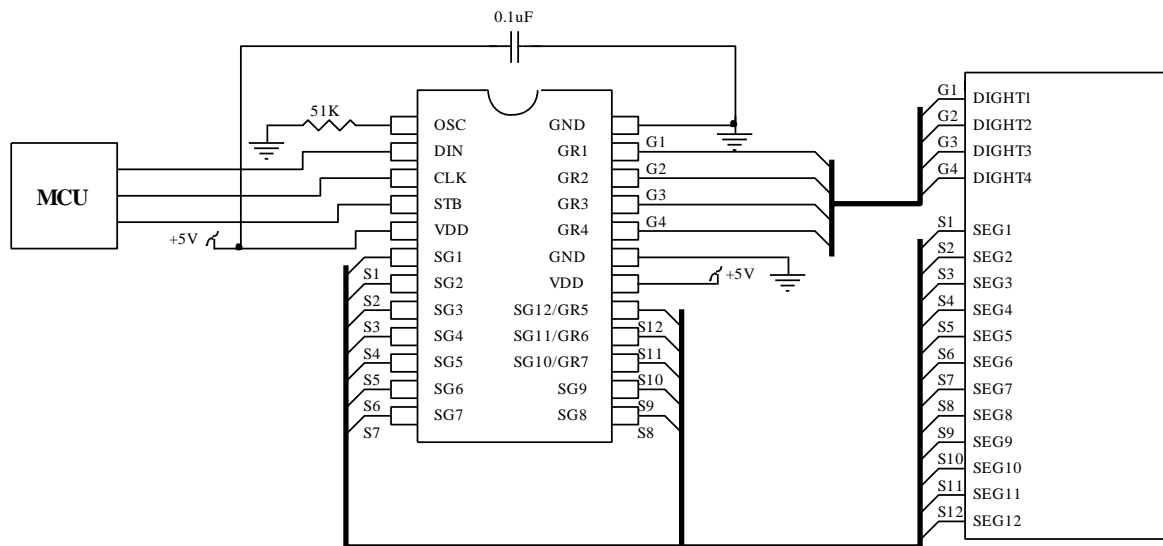

Note: The capacitor (0.1uF) connected between the GND and VDD Pins must be located as near as possible to the DL8835 chip.

COMMON CATHODE TYPE LED PANEL:

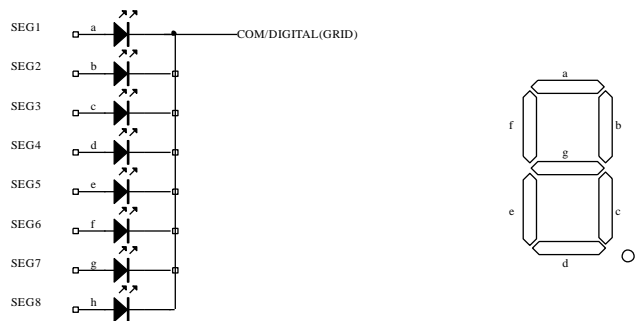



深圳市晶峰达电子科技有限公司

ShenZhen JinFengDa Electronic Technology Co., Ltd.

地址:深圳市龙岗街道 电话:0755-29206918, 13798528768



网站: www.jfd-ic.com 邮箱: info@jfd-ic.com QQ: 402431824

DL8835

LED Driver IC

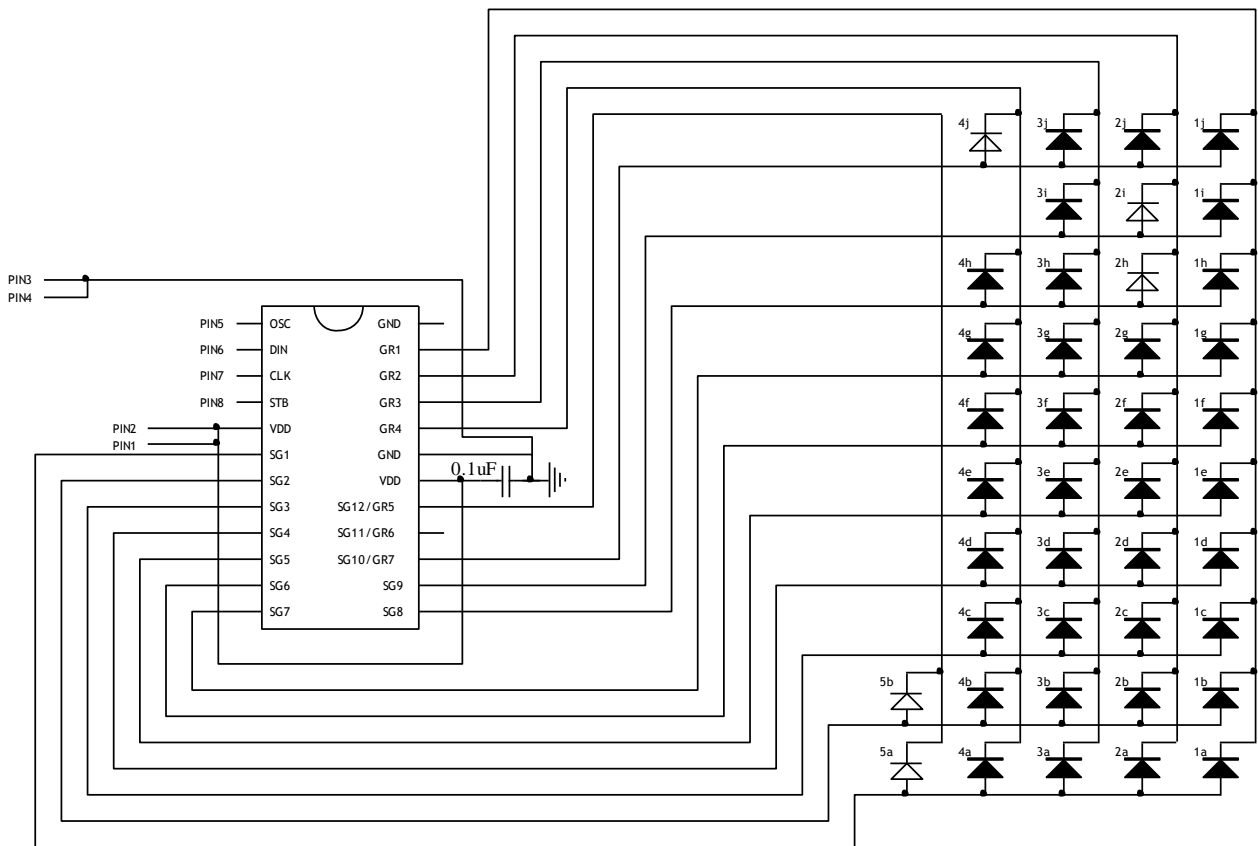
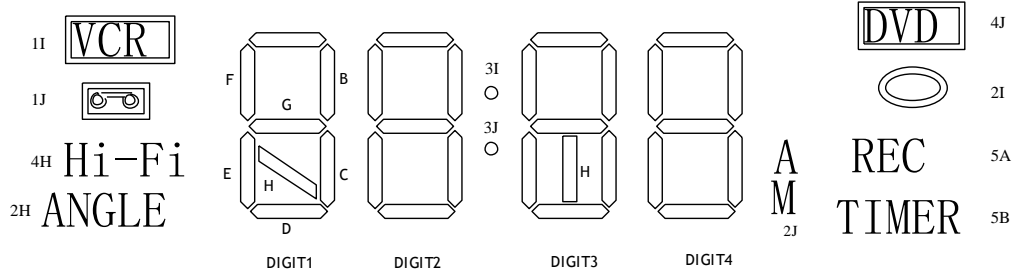
INTERNAL CIRCUIT DIAGRAM PIN CONNECTION



NOTE: THE SIGN "  " IS STANDARD FOR GREEN CHIP.
 THE SIGN "  " IS STANDARD FOR RED ORANGE CHIP.
 THE SIGN "  " IS STANDARD FOR AMBER CHIP.