



Features

- Low turn off time
- Maximum operating frequency greater than 500KHz
- Timing from microseconds to hours
- Operates in both astable and monostable modes
- High output current can source or sink 200mA
- Adjustable duty cycle
- TTL compatible
- Temperature stability of 0.005% per°C

Description

The DL6709 dual monolithic timing circuit is a highly stable controller capable of producing accurate time delays or oscillation. In the time delay mode of operation, the time is precisely controlled by one external resistor and capacitor. For a stable operation as an oscillator, the free running frequency and the duty cycle are both accurately controlled with two external resistors and one capacitor. The circuit may be triggered and reset on falling waveforms, and the output structure can source or sink up to 200mA.

Order Codes

Part Number	Temperature Range	Package	
		N	D
DL6709	0°C, 70°C	•	•

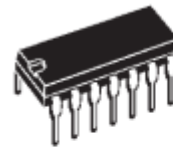

N
DIP14
(Plastic Package)



D
SO14
(Plastic Micropackage)

Pin Connections(top view)

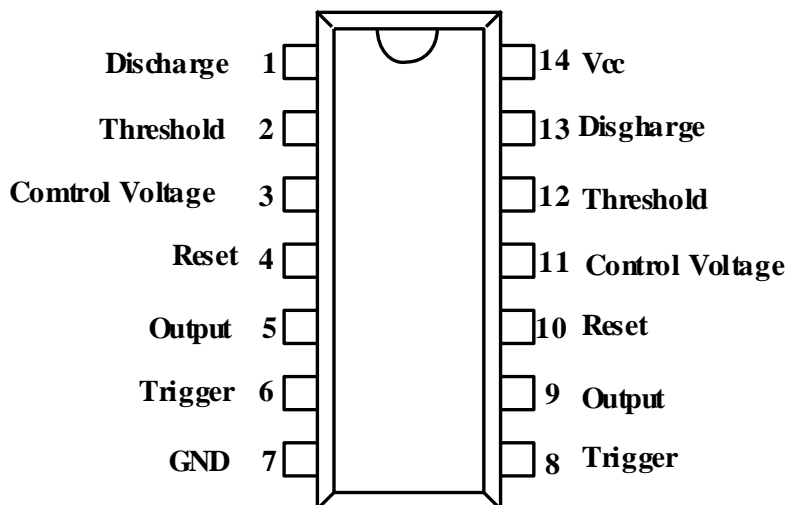



Block Diagram

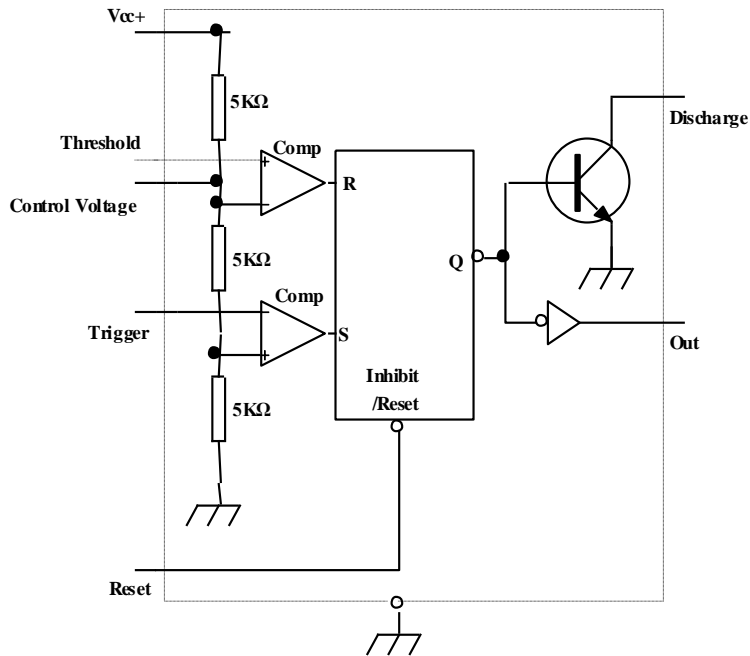

Schematic Diagram

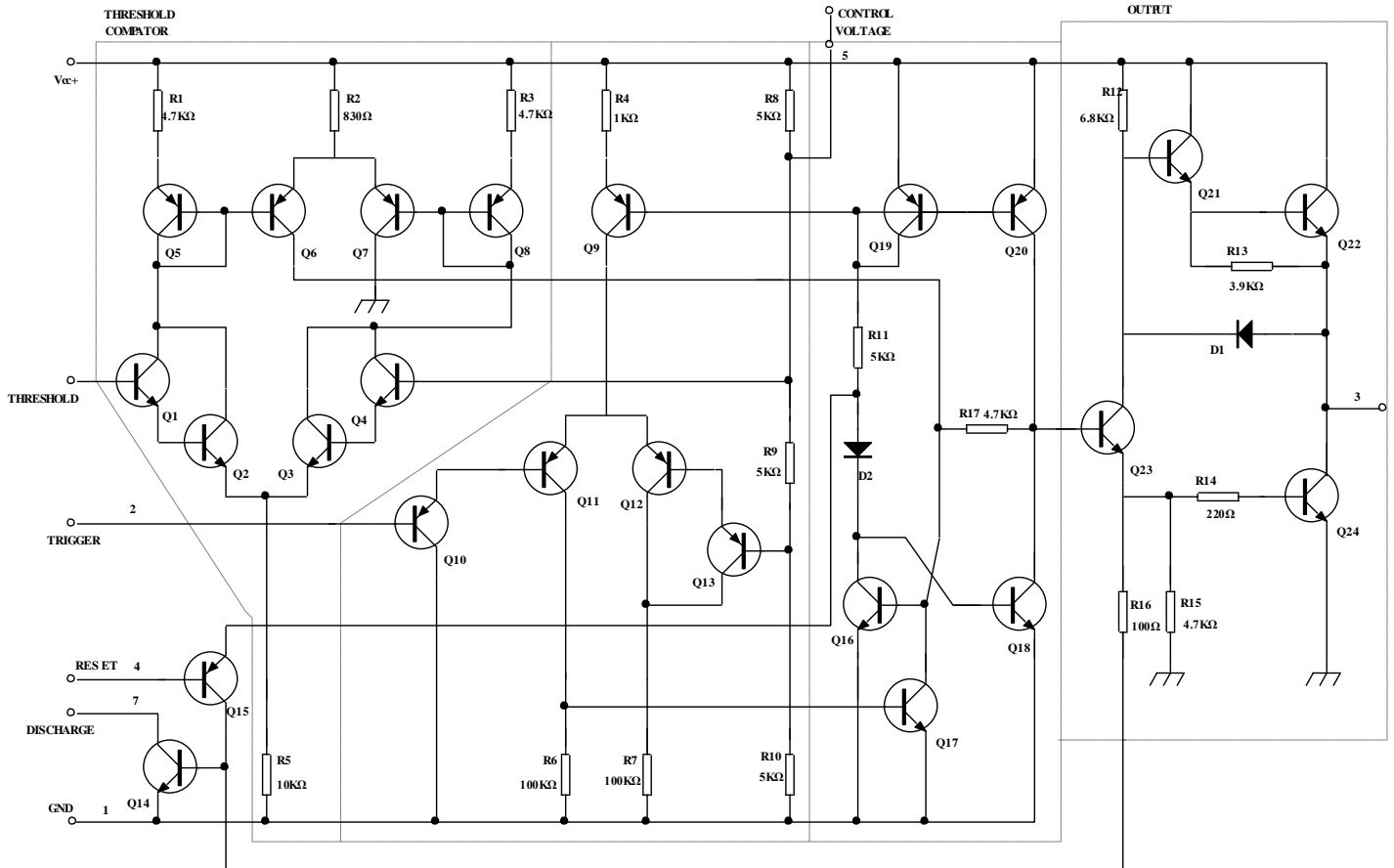



Absolute Maximum Ratings

Symbol	Parameter		Value	Unit
Vcc	Supply Voltage		18	V
Toper	Operating Free Air Temperature Range	For DL6709	0 to 70	°C
Tj	Junction Temperature		150	°C
Tstg	Storage Temperature Range		-65 to 150	°C

Operating Conditions

Symbol	Parameter	DL6709A	Unit
Vcc	Supply Voltage	4.5 to 18	V
Vth, Vtrig, Vcl, Vreset	Maximum Input Voltage	Vcc	V

Electrical Characteristics Tamb = + 25°C, Vcc = + 5V to + 15V(unless otherwise specified)

Symbol	Parameter	DL6709			Unit
		Min.	Typ.	Max.	
Icc	Supply Current(R _L ∞) (-note 1) - (2 timers)	--	1	2	mA
	Low State Vcc = + 5V	--	3	6	mA
	High State Vcc = + 15V	--	4	--	mA
	Timing Error (monostable) (R _A = 2k to 100kΩ, C = 0.1uF)	--	1	3	%
	Initial Accuracy – (note 2)	--	50	--	ppm/°C
	Drift with Temperature	--	0.1	0.5	%/V
	Timing Error (astable) (R _A , R _B = 1kΩ to 100kΩ, C = 0.1uF, Vcc = + 15V)	--	2.25	--	%
	Initial Accuracy – (note 2)	--	150	--	ppm/°C
	Drift with Temperature	--	0.3	--	%/V
V _{CL}	Control Voltage Level Vcc = + 15V	9	10	11	V
	Vcc = + 5V	2.6	3.33	4	V
V _{th}	Threshold Voltage Vcc = + 15V	8.8	10	11.2	V
	Vcc = + 5V	2.4	3.33	4.2	V
I _{th}	Threshold Current – (note 3)	--	0.1	0.25	uA
V _{trig}	Threshold Voltage Vcc = + 15V	4.5	5	5.6	V
	Vcc = + 5V	1.1	1.67	2.2	V
I _{trig}	Threshold Current (V _{trig} = 0V)	--	0.5	2.0	uA
V _{reset}	Reset Voltage – (note 4)	--	2.5	--	V
I _{reset}	Reset Current V _{reset} = + 0.4V	--	0.1	0.4	mA
	V _{reset} = 0V	--	0.4	1.5	mA
V _{OL}	Low Level Output Voltage	--	0.1	0.25	V



	Vcc = + 15V,	I _{O(sink)} = 10mA	--	0.4	0.75	V
		I _{O(sink)} = 50mA	--	2	2.5	V
		I _{O(sink)} = 100mA	--	2.5	--	V
	Vcc = + 5V,	I _{O(sink)} = 200mA	--	0.2	0.4	V
		I _{O(sink)} = 8mA	--	0.15	0.25	V
		I _{O(sink)} = 5mA	--			
V_{OH}	High Level Output Voltage		--	12.5	--	V
	Vcc = + 15v,	I _{O(source)} = 200mA	12.75	13.3	--	V
	Vcc = + 5v,	I _{O(source)} = 100mA	2.75	3.3	--	V

- Notes: 1. Supply current when output is high is typically 1mA less.
2. Tested at Vcc = + 5V and Vcc = + 15V.
3. This will determine the maximum value of R_A + R_B for + 15V operation the max total is R = 20MΩ and for 5V operation the max total R = 3.5MΩ .
4. Specified with trigger input high, VDD=5V

➤ **Electrical Characteristics** (continued)

Symbol	Parameter	DL6709			Unit
		Min.	Typ.	Max.	
I_{dis} (off)	Discharge Pin Leakage Current (output high) (V _{dis} = 10V)	--	20	100	nA
V_{dis} (sat)	Discharge pin Saturation Voltage (output low) – (note 5) Vcc = + 15V, I _{dis} = 15mA Vcc = + 5V, I _{dis} = 4.5mA	--	180	480	mA
		--	80	200	mA
t_r	Output Rise Time	--	100	300	Ns
t_r	Output Fall Time	--	100	300	Ns
T_{off}	Turn off Time – (note 6) (V _{reset} = Vcc)	--	0.5	--	us

- Notes: 1. No protection against excessive Pin 7 current is necessary, providing the package dissipation rating will not be exceeded.
2. Time measured from a positive going input pulse from 0 to 0.8x Vcc into the threshold to the drop from high to low of the output trigger is tied to threshold.



Figure 1 : Minimum Pulse Width Required for Trigering

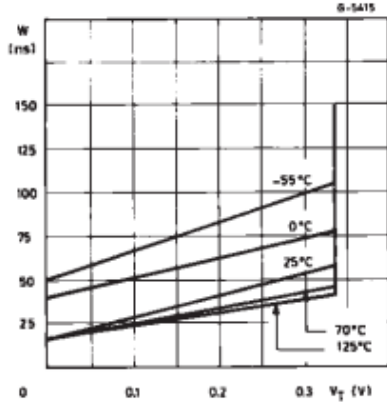

Figure 2 : Supply Current versus Supply Voltage

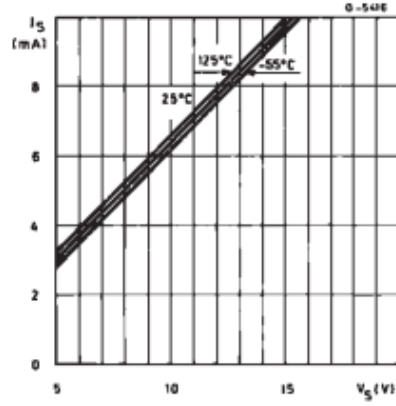

Figure 3 : Delay Time versus Temperature

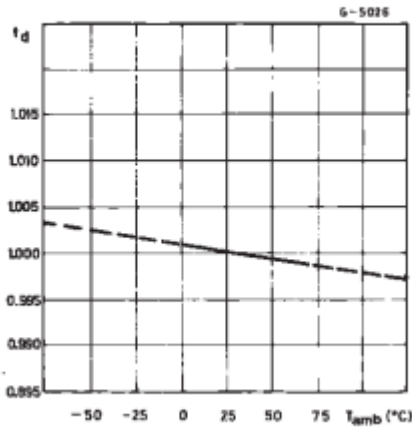

Figure 4 : Low Output Voltage versus Output Sink Current

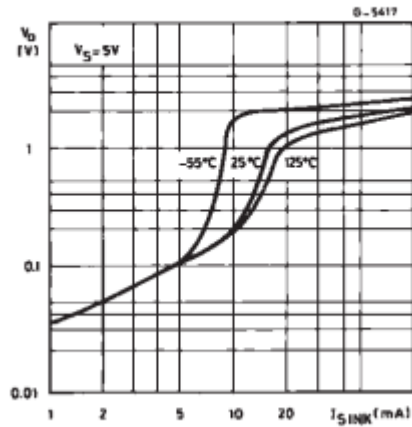

Figure 5 : Low Output Voltage versus Output Sink Current

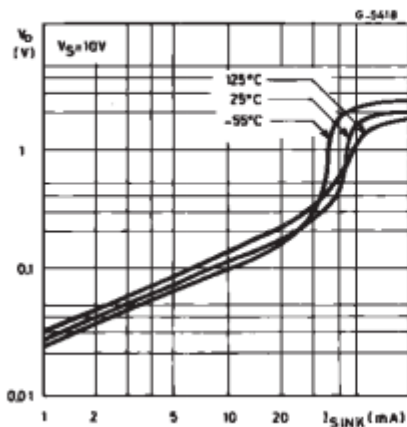

Figure 6 : Low Output Voltage versus Output Sink Current

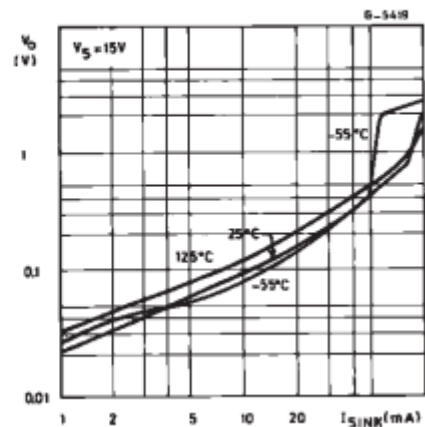



Figure 7 : High Output Voltage Drop versus Output

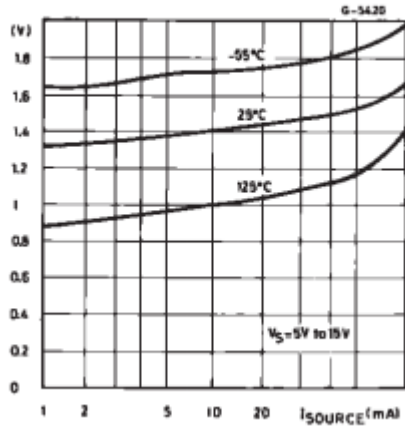

Figure 8 : Delay Time versus Supply Voltage

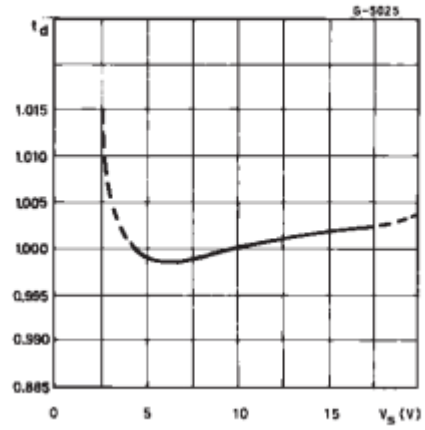
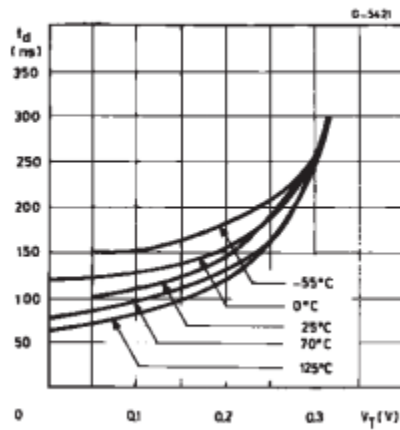

Figure 9 : Propagation Delay versus Voltage Level of Trigger Value





DL6709

定时器 IC

50% Duty Cycle Oscillator

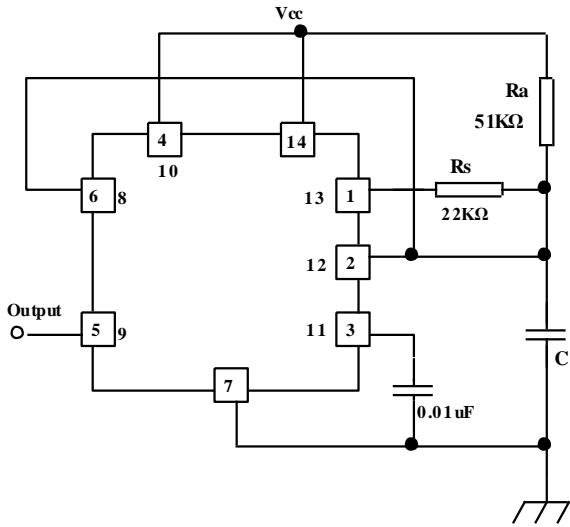

Pulse Width Modulator

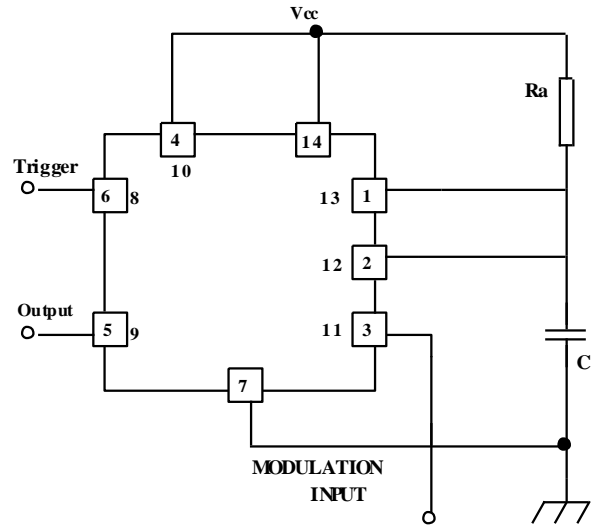

$$t_1 = 0.693 R_A \cdot C$$

$$t_2 = [(R_A R_B) / (R_A + R_B)] C \ln \left(\frac{R_B - 2R_A}{2R_B - R_A} \right)$$

$$f = \frac{1}{t_1 + t_2} R_B < \frac{1}{2} R_A \text{ ti}$$

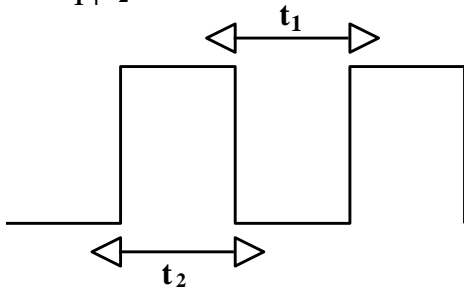



Tone Burst Generator

For a tone burst generator the first timer is used as a monostable and determines the tone duration when triggered by a positive pulse at pin 6. The second timer is enabled by the high output of the monostable. It is connected as an astable and determines the frequency of the tone.

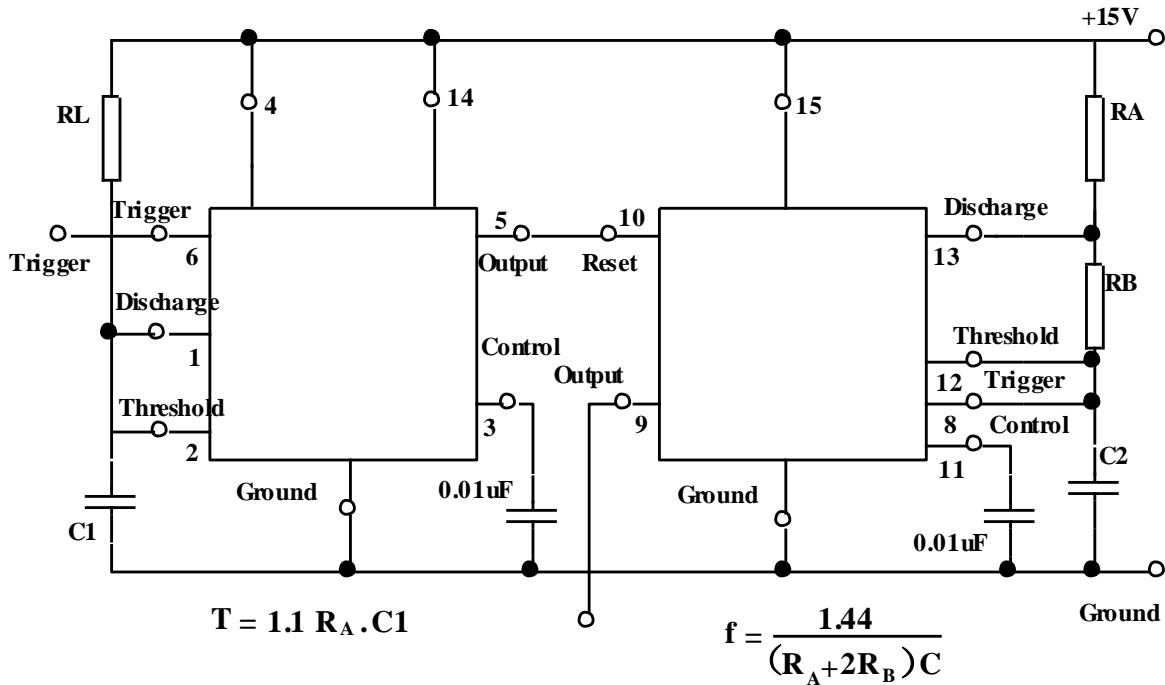

Astable Operation

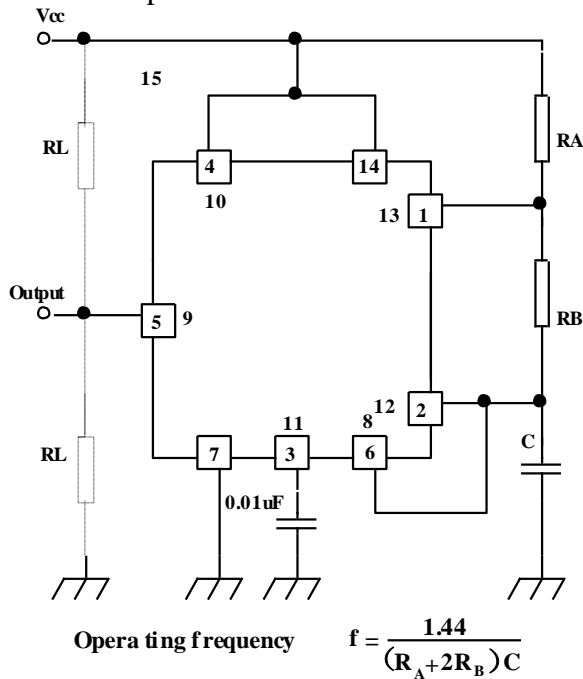

Monostable Operation

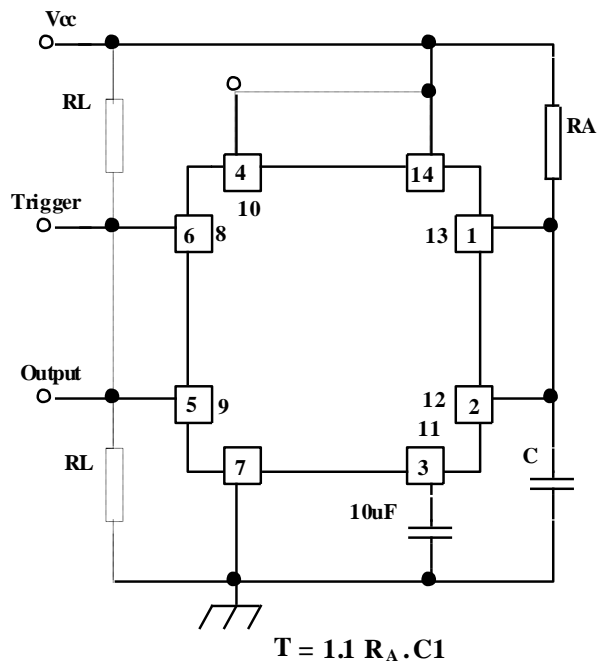



$t_1 = 0.693 (R_A + R_B)C$ Output High

$t_1 = 0.693 R_B C$ Output High

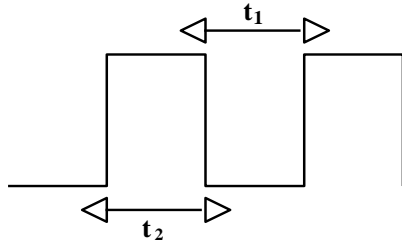

PACKAGE MECHANICAL DATA

14 PINS - PLASTIC DIP

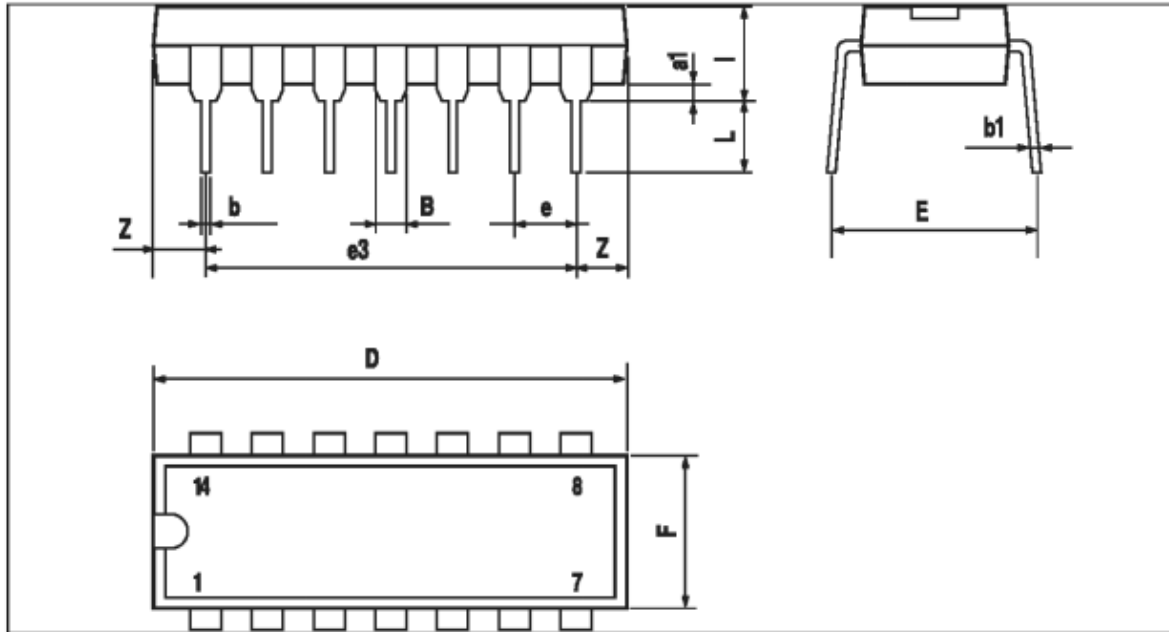

Dimensions	Millimeters			Inches		
	Min.	Typ.	Max.	Min.	Typ.	Max.
a1	0.51	--	--	0.020	--	0.065
B	1.39	--	1.65	0.055	--	--
b	--	0.5	--	--	0.020	--
b1	--	0.25	--	--	0.010	--
D	--	--	20	--	--	0.787
E	--	8.5	--	--	0.335	--
e	--	2.54	--	--	0.100	--
e3	--	15.24	--	--	0.600	--
F	--	--	7.1	--	--	0.280
I	--	--	5.1	--	--	0.201
L	--	3.3	--	--	0.130	--
Z	1.27	--	2.54	0.050	--	0.100

14 PINS - PLASTIC MICROPACKAGE (SO)

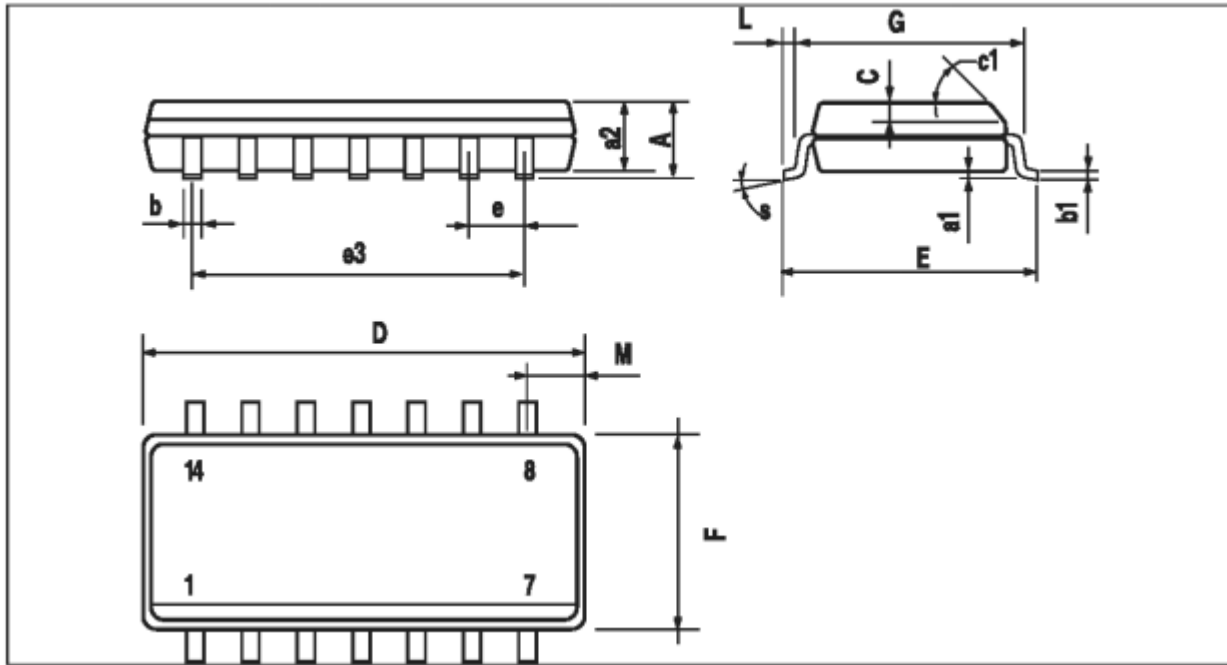

Dimensions	Millimeters			Inches		
	Min.	Typ.	Max.	Min.	Typ.	Max.
A	--	--	1.75	--	--	0.069
a1	0.1	--	0.2	0.004	--	0.008
a2	--	--	1.6	--	--	0.063
b	0.35	--	0.46	0.014	--	0.018
b1	0.19	--	0.25	0.007	--	0.010
C	--	0.5	--	--	0.020	--
c1	45° (typ.)					
D	8.55	--	8.75	0.336	--	0.334
E	5.8	--	6.2	0.228	--	0.244
e	--	1.27	--	--	0.050	--
e3	--	7.62	--	--	0.300	--
F	3.8	--	4.0	0.150	--	0.157
G	4.6	--	5.3	0.181	--	0.208
L	0.5	--	1.27	0.020	--	0.050
M	--	--	0.68	--	--	0.027
S	8° (max)					