



**深圳市晶峰达电子科技有限公司**  
ShenZhen JinFengDa Electronic Technology Co., Ltd.  
地址:深圳市龙岗街道 电话:0755-29206918, 13798528768  
网站:www.jfd-ic.com 邮箱:info@jfd-ic.com QQ:402431824

## DL6153 六位带冷光 IC

# 产 品 说 明 书

**FEATURES**

- Drives 6-digit duplexed LCD with 7-day mark, AM/PM, date and alarm
- Hour, Minute, Second, Day-of Week, Colon, Month and Date display
- Split operative stopwatch (accurate to 1/100 second)
- Direct drive of piezoelectric transducer
- 32,768Hz crystal frequency
- On chip oscillator, capacitor, resistor, voltage halfer
- Single 3.0V batter operation
- Low power dissipation
- Debounce circuitry on switch inputs
- Protection against static discharge
- Signals to drive EL backlight with delay function

**FUNCTIONS**

- 6 Functions: Month, Date, Day-of-Week, Hour, Minute, Second
- 6-digit Chronograph: Auto-ranging after 30 minutes to hour, minute; second. From minute, second 1/100 second
- Alarm output for melody IC (KS5381 series)
- Alarm function with 4 to 5 minutes snooze
- User selectable 12-hour/24-hour format
- 4-year calendar
- One-touch correction of time error within  $\pm 30$  seconds
- Fast advance for time and alarm time set
- Chime on every hour
- Switch operation
- LCD test

**DESCRIPTION**

The 6153 is a CMOS digital 6-function watch integrated circuit with a 6-digit LCD watch and built-in alarm/chronograph Function. The LCD display has a capacity of 6 digits, 7 day mark, AM/PM mark and colon. The watch circuit time base is a 32,768 kHz crystal oscillator. Oscillator RC network components are included on the chip, 25 phase segment outputs and 2 phase backplane outputs are provided for LCD. An on-chip halfer is used to generate the LCD drive voltage.

The 6153 designed especially for use with 3V Li-battery.

The 6153 provides signals to drive EL backlight.

**注：在设计时晶振应尽量靠近IC, 晶振线要尽量短点**

**ABSOLUTE MAXIMUM RATINGS**

Characteristic	Symbol	Value	Unit
Supply Voltage, $V_{CC}$	$V_{CC}$	- 0.3 ~ + 4.0	V
Operating Temperature	$T_{opr}$	- 20 ~ + 70	°C
Storage Temperature	$T_{stg}$	- 55 ~ + 125	°C

**ELECTRICAL CHARACTERISTICS**

( $T_a = 25^\circ\text{C}$ ,  $V_{SS} = 0\text{V}$ ,  $V_{CC} = 3.0\text{V}$  unless otherwise specified)

Characteristic	Symbol	Test Condition	Min	Typ	Max	Unit
Operating Voltage	$V_{CC}$		2.4	3.0	3.3	V
Supply Current	$I_{CC}$	Without load		1.5	2.5	$\mu\text{A}$
Oscillator Start Voltage	$V_{OSC}$				2.7	V
Alarm Drive Current (BD, BDN)	$I_O$	$V_{sat} = 0.5\text{V}$ (Both Direction)	0.5	2		mA
Pump Frequency	$F_{PUMP}$	IND Output		32,768		Hz
EL Frequency	$F_{EL}$	EL Output		512		Hz
Oscillator Input and Output Capacitors	$C_{IN}, C_{OUT}$			20		pF
Output Voltage for EL Drive	$V_{EL}$	$V_{CC}=3\text{V}$		110		V

LCD FORMAT

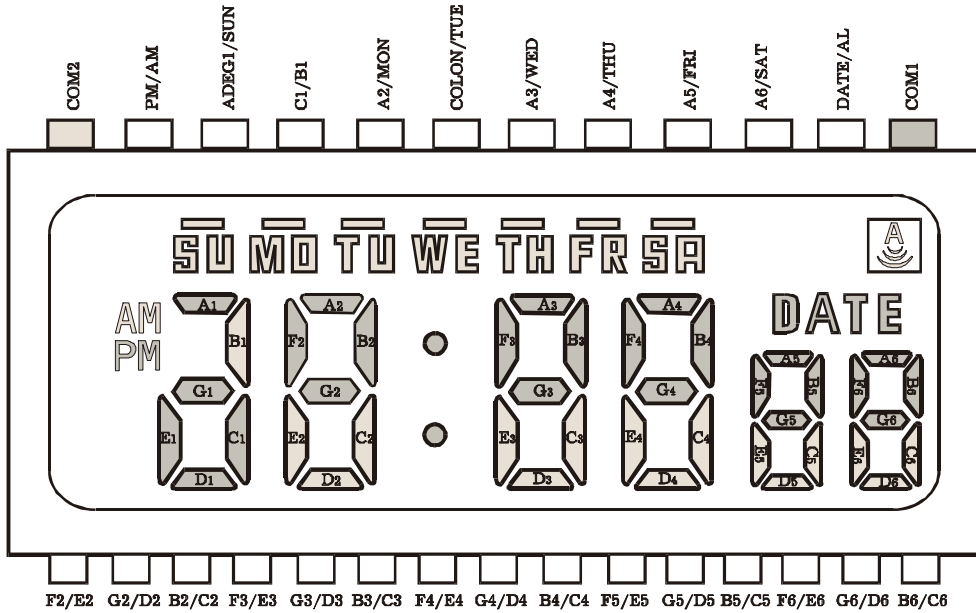

SETTING SEQUENCE AND SWITCH OPERATION

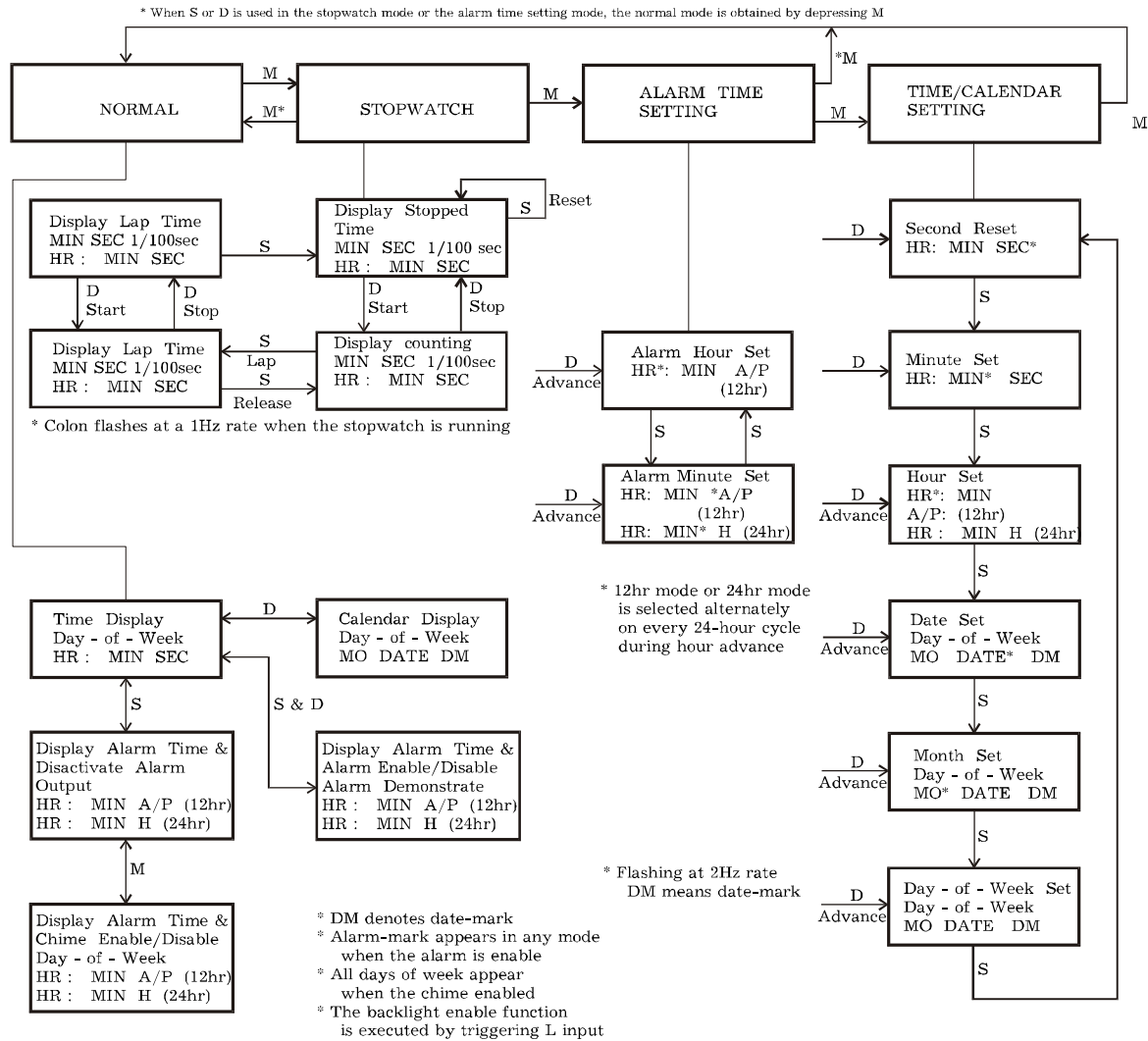

ALARM OUTPUT WAVEFORM

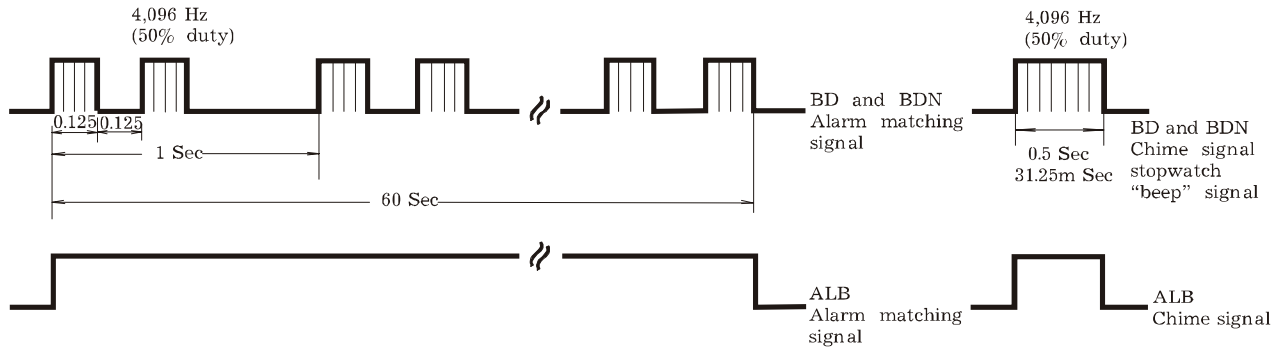

ELECTROLUMINESCENT LAMP OUTPUT WAVEFORM

- IF PUSH L BUTTON ONCE

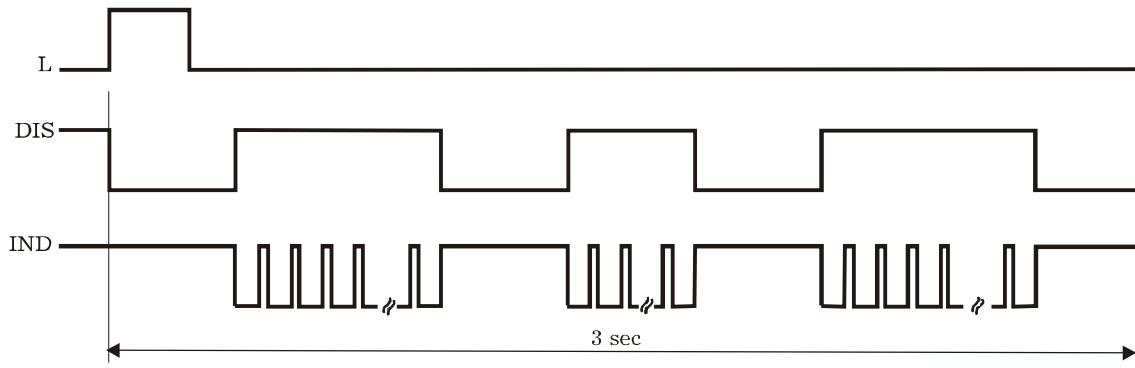

- IF BUTTON IS HOLD LONGER THEN 3 SECONDS

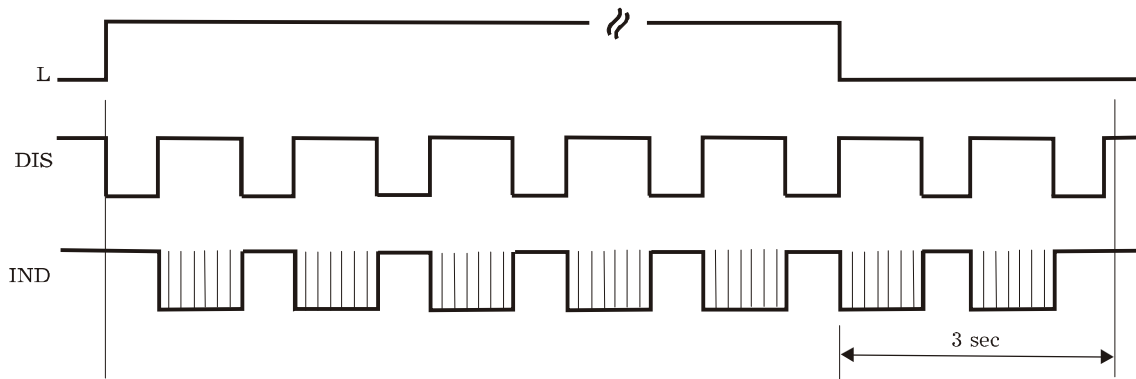

APPLICATION CIRCUIT

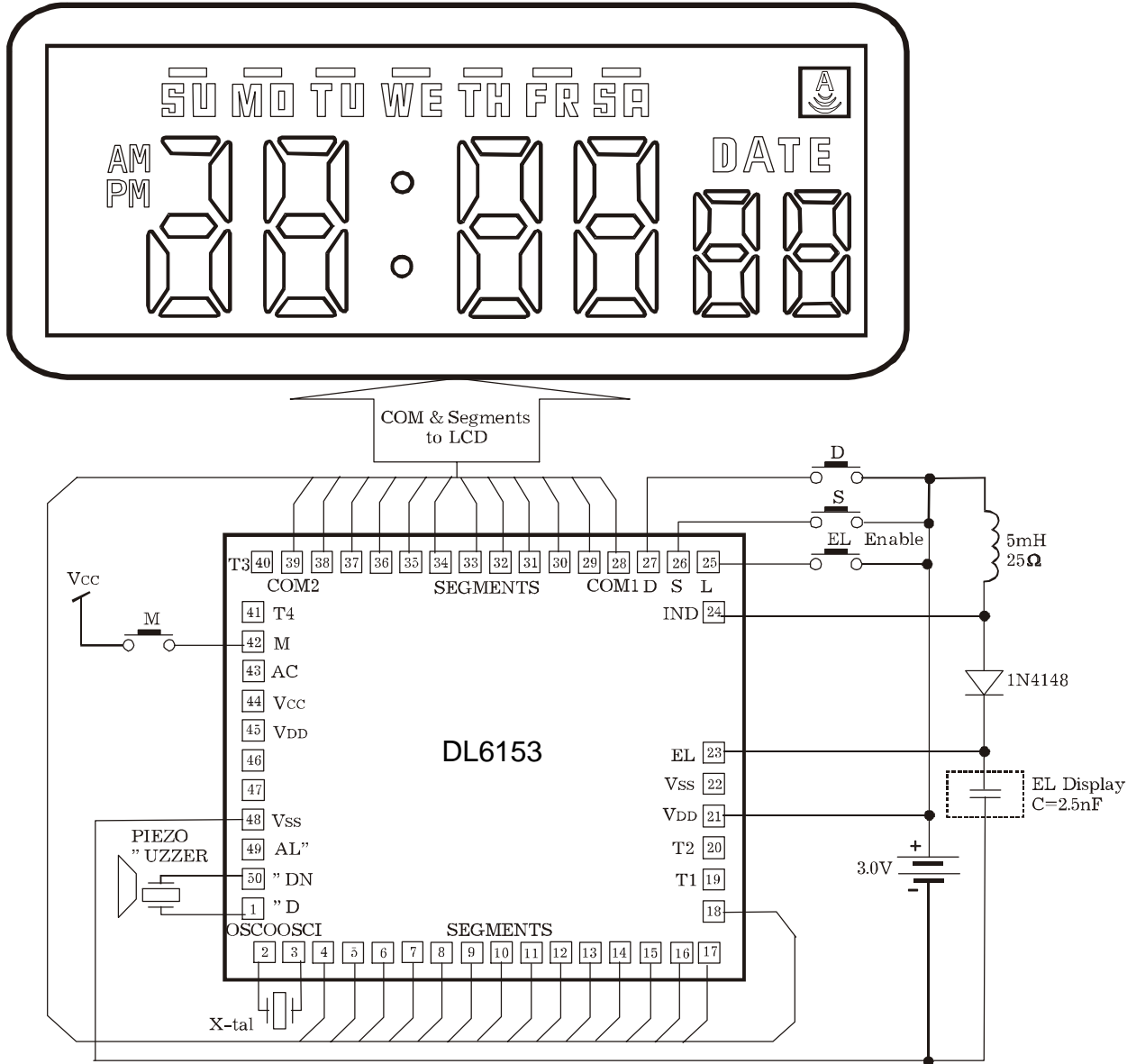

注：在设计时晶振应尽量靠近IC, 晶振线要尽量短点, 当PCB走线存在干扰时, 请在L, S, D制位各加104电容至VSS线路

NOTE: The chip substrate is electrically connected to VSS.

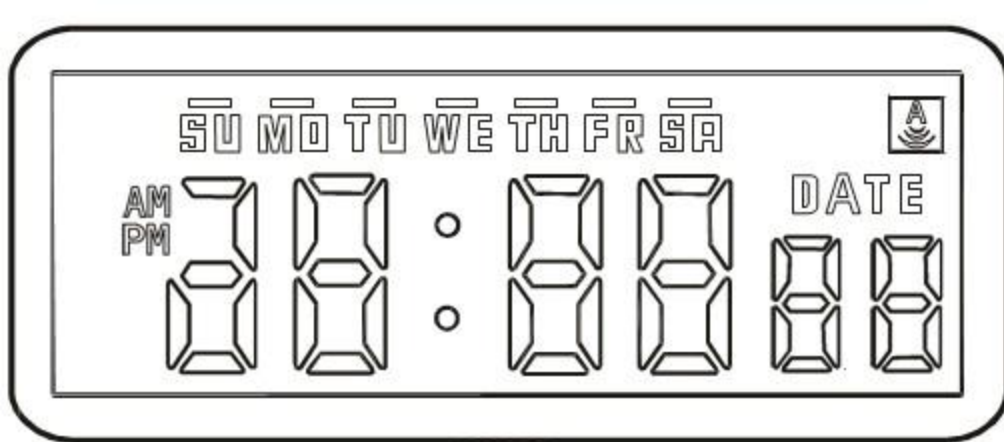

注：在设计时晶振应尽量靠近IC，晶振线要尽量短点，当PCB走线存在干扰时，请在L，S，D制位各加104电容至VSS线路

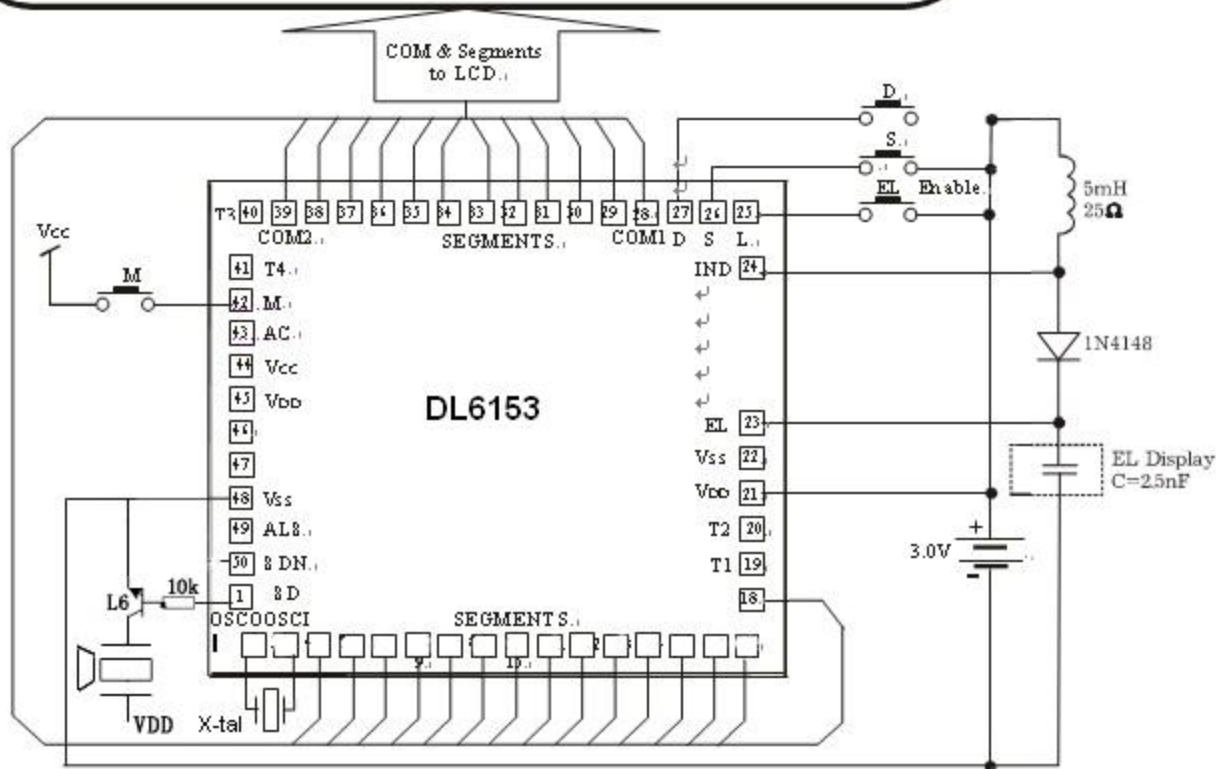

防止接蜂鸣片时白板的接法,加L6和10K电阻

PAD DIAGRAM

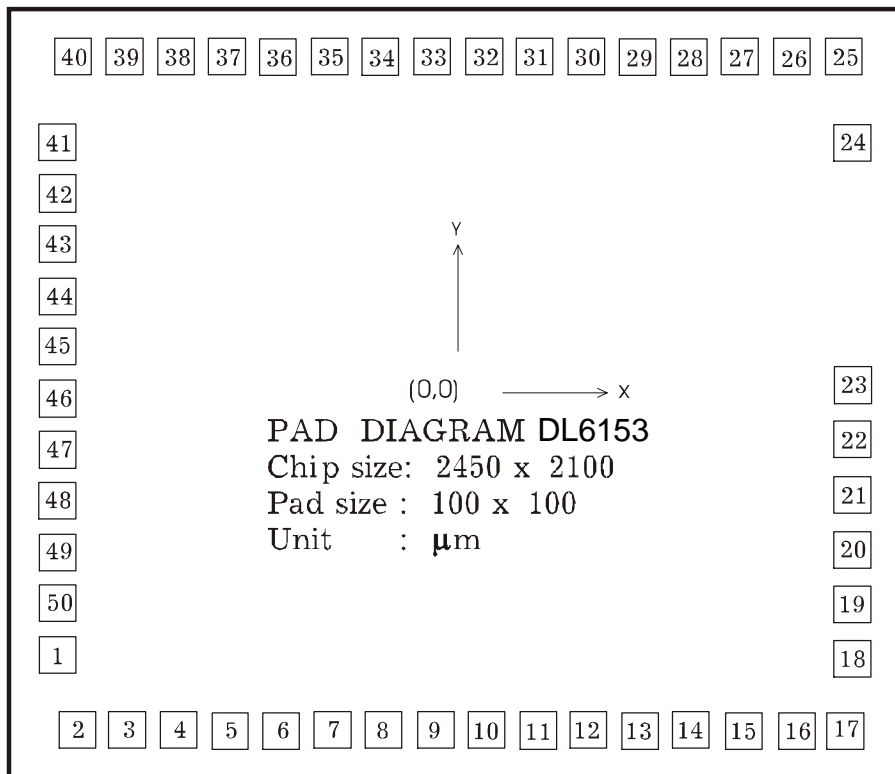

NOTE: The chip substrate is electrically connected to V<sub>SS</sub>.

PAD LOCATION

Pad No.	Pad Name	X	Y	Pad No.	Pad Name	X	Y	Pad No.	Pad Name	X	Y
1	" D	-1090	-713	18	" 6/C6	1080	-725	35	A2/MON	-349	920
2	OSCO	-1040	-920	19	T1	1080	-575	36	C1/" 1	-489	920
3	OSCI	-900	-920	20	T2	1080	-425	37	ADEG1/SUN	-629	920
4	F2/E2	-760	-920	21	V <sub>DD</sub>	1080	-275	38	PM/AM	-769	920
5	G2/D2	-620	-920	22	V <sub>SS</sub>	1080	-125	39	COM2	-909	920
6	" 2/C2	-480	-920	23	EL	1080	25	40	T3	-1049	920
7	F3/E3	-340	-920	24	IND	1080	684	41	T4	-1090	687
8	G3/D3	-200	-920	25	L	1051	920	42	M	-1090	547
9	" 3/C3	-60	-920	26	S	911	920	43	AC	-1090	407
10	F4/E4	80	-920	27	D	771	920	44	V <sub>CC</sub>	-1090	267
11	G4/D4	220	-920	28	COM1	631	920	45	V <sub>DD</sub>	-1090	127
12	" 4/C4	360	-920	29	DATE/AL	491	920	46	NC	-1090	-13
13	F5/E5	500	-920	30	A6/SAT	351	920	47	NC	-1090	-153
14	G5/D5	640	-920	31	A5/FRI	211	920	48	V <sub>SS</sub>	-1090	-293
15	" 5/C5	780	-920	32	A4/THU	71	920	49	AL"	-1090	-433
16	F6/E6	920	-920	33	A3/WED	-69	920	50	" DN	-1090	-573
17	G6/D6	1060	-920	34	COLON/TUE	-209	920				