



深圳市晶峰达电子科技有限公司
ShenZhen JinFengDa Electronic Technology Co., Ltd.
地址:深圳市龙岗街道 电话:0755-29206918, 13798528768
网站:www.jfd-ic.com 邮箱:info@jfd-ic.com QQ:402431824

DL6018 六位多功能手表 IC

产
品
规
格
书

Multifunctional CMOS IC For Electronic Watch With Temperature Measurement Function

The DL6018 is a CMOS IC with functions of electronic watch, of thermometer °C/ °F with a range of measurement from -20°C up to + 60°C (-4°F up to + 140°F), alarm clock, stop watch, hourly audio signal, LCD with mark of month, date , days of week, Am, Pm, Alarm, °C, °F and colon.

FEATURES

- Control over Liquid Crystal Display (LCD) in four-level multiplexing mode;
- Colon display;
- Control of piezoelectric transducer
- Embedded-in-chip elements of quartz generator with operation frequency 32768 Hz, capacity, resistor and voltage doubler;
- Operation with one 3.0V battery, low consumption power;
- Circuits of contacts chatter suppression on button inputs;
- Protection against static electricity

FUNCTIONS

- 6 functions of counting time and calendar with readings of hours, minutes, seconds, months, dates, days of week;
- 6-bit stop-watch with counting discreteness one hundredth second;
- Alarm clock with function of repeat of signal every 5 minutes;
- Thermometer temperature measurement range: from -20 up to +60°Ñ from -4 up to +140°F;
- User's choice of 12/24 hours time scale.

LCD FORMAT

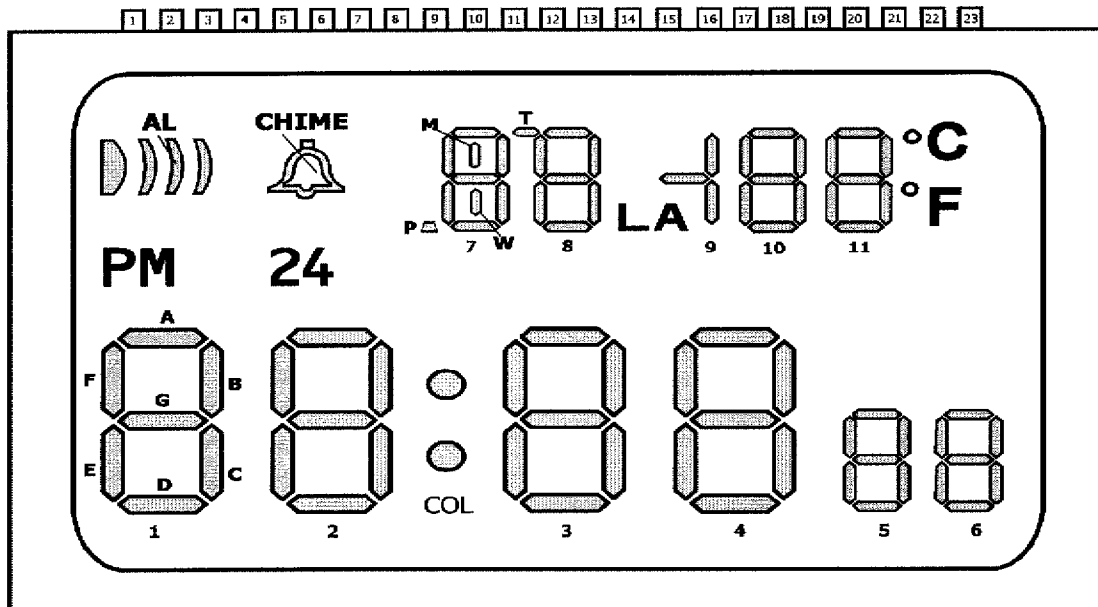

DL6018

ABSOLUTE MAXIMUM RATINGS (operation temperature range is form -20°N up to $+75^{\circ}\text{N}$)

Characteristic	Symbol	Extreme Limit		Guaranteed Limit		Unit
		Min	Max	Min	Max	
Supply voltage from voltage source	U_{DD}	2,4	3,6	-0,3	4,0	V
Supply voltage from voltage converter	U_{CC}	3,6	5,4	-0,3	6,0	V
High-level input voltage	U_{IH}	$U_{DD}-0,3$	U_{DD}	-0,3	$U_{DD}+0,3$	V
Low-level input voltage	U_{IL}	U_{SS}	$U_{SS}+0,3$	-0,3	$U_{DD}+0,3$	V

Under limiting modes efficiency of ICs is not guaranteed. After limiting modes are cancelled the operation in extreme mode is guaranteed.

ELECTRICAL CHARACTERISTICS ($T_a = 25^{\circ}\text{C}$)

Parameter	Symbol	Test Conditions	Guaranteed Limit		Note	Unit
			Min	Max		
Dynamic consumption current	I_{DD}	$U_{DD}=3,0\text{V}$	-	3,0	1,4	mkA
Buttons switch current	I_{sw}	$U_{DD}=3,0\text{V}$ $U_{IN}=U_{DD}$	0,1	30	-	mkA
Low-level output current on pins ALA , ALB	I_{OL}	$U_{OL}=0,5\text{V}$ $U_{DD}=2,4\text{V}$	500	-	-	mkA
High-level output current on pins ALA , ALB	I_{OH}	$U_{OH}=1,9\text{V}$ $U_{DD}=2,4\text{V}$	-500	-	3	mkA
Generator starting voltage	U_{osc}	control time 5sec	-	2,4	4	V

Notes:

1 Dynamic consumption current is measured without load.

2 Nominal value of embedded capacities on pins OSC1 and OSC0 (generator's input and output) - 20 pF.

3 «Minus» specifies only current direction.

4 Parameters are controlled with quarts resonator, ensuring series resonance frequency 32768 Hz at load capacity value $C_L=10\text{ pF}$.

CONTROL SIGNALS OF LCD SEGMENTS

¹ SEG	COM0	COM1	COM2	COM3	¹ SEG	COM0	COM1	COM2	COM3
0	-	F5	E5	D5	12	-	C7	B7	M7
1	A5	B5	G5	C5	13	D7	W7	G7	A7
2	-	F6	E6	D6	14	P7	E7	F7	-
3	A6	B6	G6	C6	15	A4	B4	C4	-
4	-	$^{\circ}\text{F}$	$^{\circ}\text{C}$	B11	16	F4	G4	E4	D4
5	-	C11	G11	A11	17	A3	B3	C3	-
6	D11	E11	B10	F11	18	F3	G3	E3	D3
7	C10	G10	F10	A10	19	-	B2	COL	C2
8	D10	E10	BC9	-	20	24H	A2	G2	D2
9	-	LAP	G9	-	21	CHIME	B1	F2	E2
10	D8	C8	B8	A8	22	PM	A1	G1	C1
11	E8	G8	F8	T8	23	AL	F1	E1	D1

DL6018

APPLICATION CIRCUIT

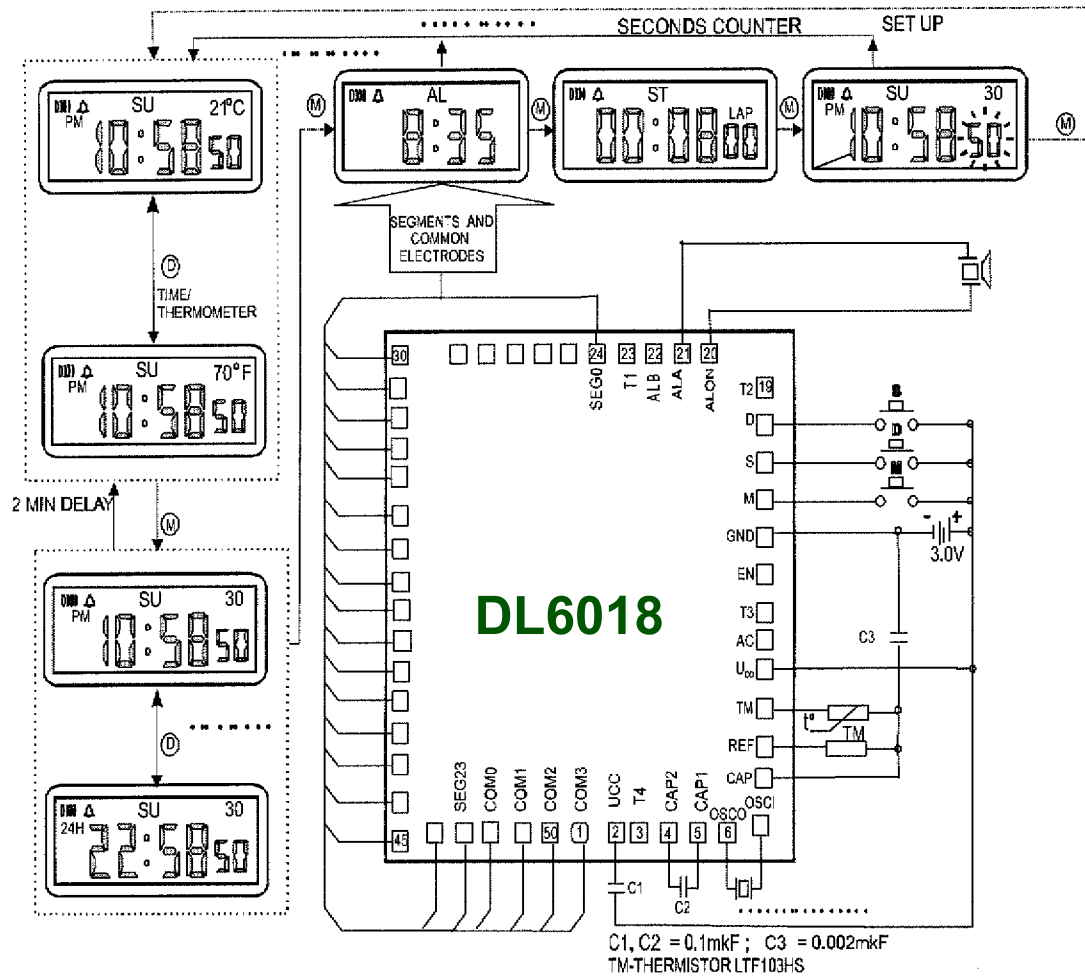

Quartz resonator parameters

$F_p = 32768\text{Hz}$

$C_L = 10.0\text{pF}$

$C_1 = 0.004\text{ pF}$

$C_o = 2.5\text{pF}$

$R_s = 35\text{k}\Omega$

$Q = 35000$

PAD DISCRIPTION

Pad	Name Pad	Discription	Pad	Name Pad	Discription
01	COM3	Common GLI control electrode	26	SEG2	LCI digit electrode
02	Ucc	Supply output from voltage converter	27	SEG3	LCI digit electrode
03	Ò4	Input of accelerated control	28	SEG4	LCI digit electrode
04	CAP2	Voltage converter output	29	SEG5	LCI digit electrode
05	CAP1	Voltage converter output	30	SEG6	LCI digit electrode
06	OSCO	Oscillator output	31	SEG7	LCI digit electrode
07	OSCI	Oscillator input	32	SEG8	LCI digit electrode
08	ÑÄÐ	Test oscillator input	33	SEG9	LCI digit electrode
09	REF	Test oscillator output	34	SEG10	LCI digit electrode
10	TM	Test oscillator output	35	SEG11	LCI digit electrode
11	U _{DD}	Supply output from voltage source	36	SEG12	LCI digit electrode
12	AC	Output of accelerated control	37	SEG13	LCI digit electrode
13	T3	Output of accelerated control	38	SEG14	LCI digit electrode
14	EN	Control input	39	SEG15	LCI digit electrode
15	V _{SS}	Common supply output	40	SEG16	LCI digit electrode
16	M	Control input	41	SEG17	LCI digit electrode
17	S	Control input	42	SEG18	LCI digit electrode
18	D	Control input	43	SEG19	LCI digit electrode
19	T2	Input of accelerated control	44	SEG20	LCI digit electrode
20	U _{DD}	Supply output from voltage source	45	SEG21	LCI digit electrode
21	ALA	Audio signal control output	46	SEG22	LCI digit electrode
22	ALB	Audio signal control output	47	SEG23	LCI digit electrode
23	TI	Accelerated control input	48	COM0	Common GLI control electrode
24	SEG0	LCI digit electrode	49	COM1	Common GLI control electrode
25	SEG1	LCI digit electrode	50	COM2	Common GLI control electrode

DL6018

PAD DIAGRAM

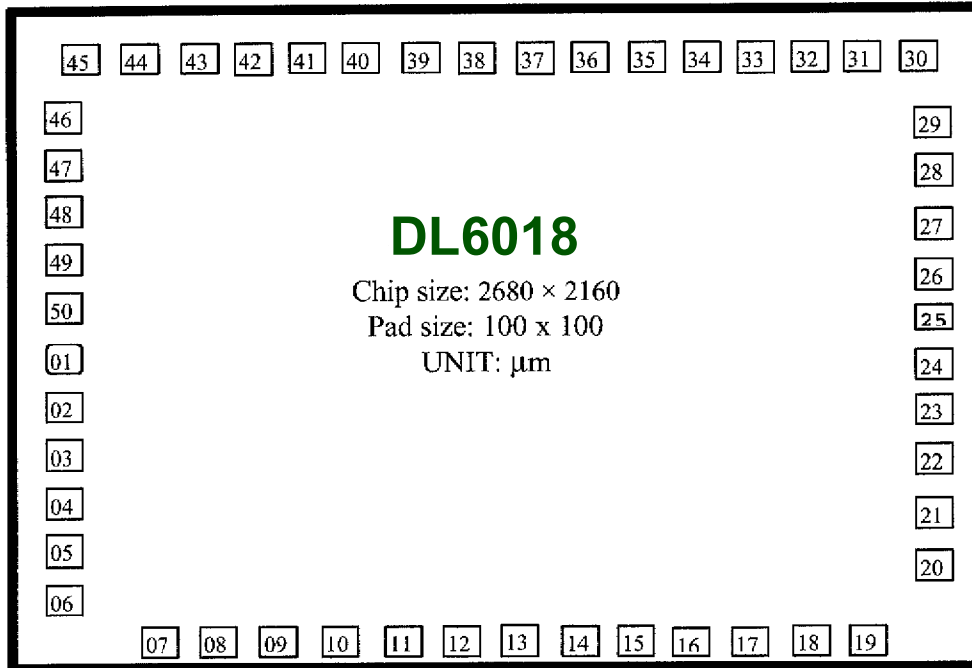

PAD LOCATION

Pad No.	Pad Name	X	Y	Pad No.	Pad Name	X	Y	Pad No.	Pad Name	X	Y
01	COM3	0.105	1.006	18	D	2.023	0.105	35	SEG11	1.661	1.955
02	Ucc	0.105	0.843	19	T2	2.174	0.105	36	SEG12	1.510	1.955
03	Ò4	0.105	0.693	20	U _{DD}	2.467	0.378	37	SEG13	1.360	1.955
04	CAP2	0.105	0.542	21	ALA	2.467	0.528	38	SEG14	1.210	1.955
05	CAP1	0.105	0.392	22	ALB	2.467	0.678	39	SEG15	1.059	1.955
06	OSCO	0.105	0.242	23	T1	2.467	0.829	40	SEG16	0.909	1.955
07	OSCI	0.369	0.105	24	SEG0	2.467	0.979	41	SEG17	0.758	1.955
08	ÑAD	0.519	0.105	25	SEG1	2.467	1.130	42	SEG18	0.608	1.955
09	REF	0.670	0.105	26	SEG2	2.467	1.280	43	SEG19	0.458	1.955
10	TM	0.820	0.105	27	SEG3	2.467	1.430	44	SEG20	0.307	1.955
11	U _{DD}	0.970	0.105	28	SEG4	2.467	1.581	45	SEG21	0.157	1.955
12	AC	1.121	0.105	29	SEG5	2.467	1.731	46	SEG22	0.105	1.746
13	T3	1.271	0.105	30	SEG6	2.413	1.940	47	SEG23	0.105	1.595
14	EN	1.422	0.105	31	SEG7	2.262	1.955	48	COM0	0.105	1.445
15	Vss	1.572	0.105	32	SEG8	2.112	1.955	49	COM1	0.105	1.294
16	M	1.722	0.105	33	SEG9	1.962	1.955	50	COM2	0.105	1.144
17	S	1.873	0.105	34	SEG10	1.811	1.955				