



东莞市琪芯电子有限公司

电话: 13798528768, 0769-81555915 传真: 85338927
 邮箱: info@jfd-ic.com, QQ: 1873357672
 网址: www.jfd-ic.com 微信号: dgqxdz
 Skype: junfuyu 阿里旺旺: qxmalcn
 微信公众号: 东莞市琪芯电子有限公司



微信公众号



扫码加微信

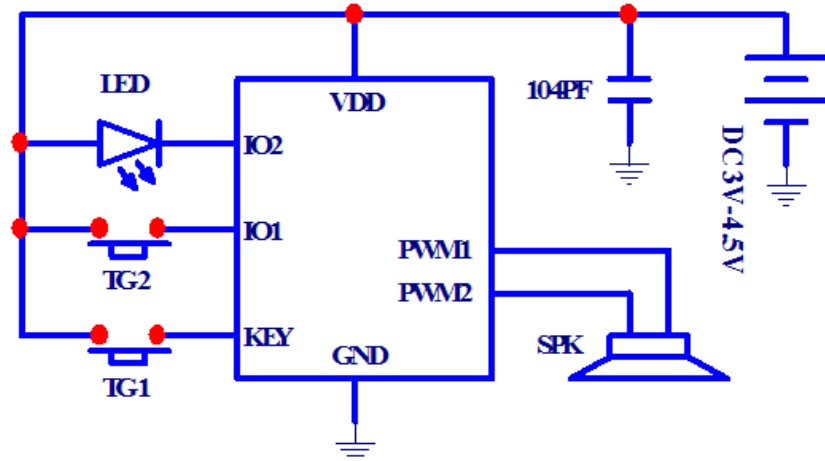
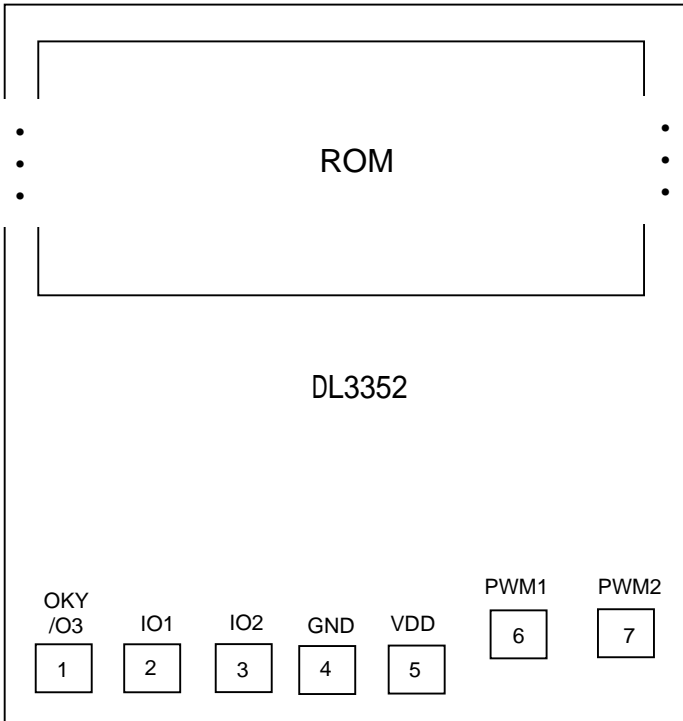

正触发
DL3352

(0, 0)

Chip size: X=828 um, Y=848 um

Pad size: 80 um x 80 um

Pad No.	Pad Name	X	Y
1	OKY/O3	80	102
2	IO1	185	102
3	IO2	290	102
4	GND	395	99
5	VDD	500	99
6	PWM1	617	175
7	PWM2	745	175

* IC substrate must be connected to GND or floating.