

**DL1078**

## 宽温度IC



ON/OFF

C / F

MAX/MIN

HOLD

**FEATURES**

- 1.5v Operate
- Single BBQ FORK Temperature Measurement
- Low Standby Current
- Low Operating Current
- Measuring Temperature Range : -50 ~ +300 degC
  - Display Resolution: 0.1 degC (Temp<100 degC)
  - Display Resolution: 0.5 degC (Temp>100 degC)
- Measurement Accuracy(Depend on temp sensor) :
  - +/- 1 degC at -20~100 degC
  - +/- 2 degC at -40 ~ -20 degC, 100~200 degC
  - +/- 5 degC at other measurement range
- Selectable for degC /degF
- Bonding option: ~45mins Time out or No Time out

# DL1078

宽温度IC

## KEY OPERATIONS

ON/OFF



C/F



HOLD



MAX/MIN

press the max/min button ,Each press will change the display MAX > MIN > and then the sequence repeats)

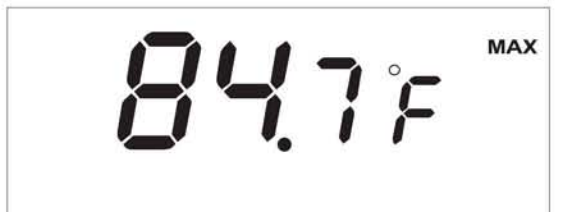

# DL1078

# 宽温度IC

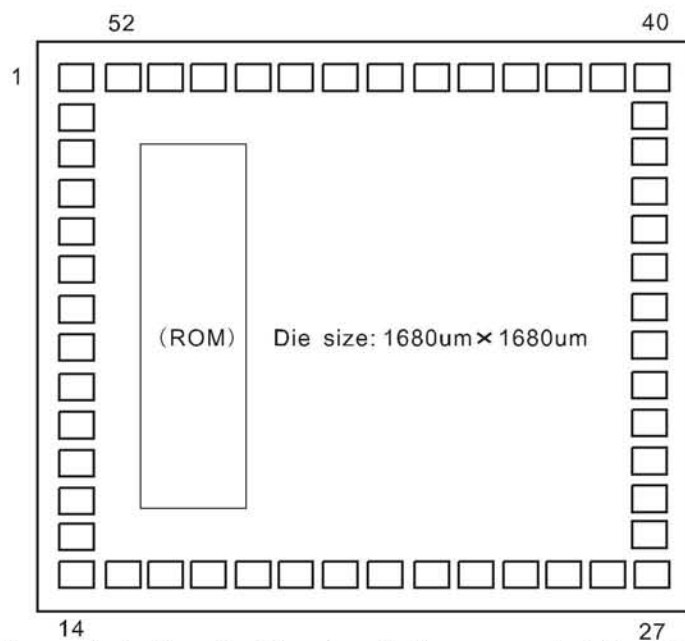

The substrate of chip should be connected to GND.

NO	NAME	X	Y	NO	NAME	X	Y
1	N.C.	77.5	1602.5	27	SEG13	1602.5	77.5
2	N.C.	77.5	1472.5	28	SEG14	1602.5	207.5
3	N.C.	77.5	1357.5	29	N.C.	1602.5	322.5
4	GND	77.5	1242.5	30	SEG15	1602.5	437.5
5	VDD1	77.5	1127.5	31	P0	1602.5	552.5
6	VL2A	77.5	1012.5	32	N.C.	1602.5	667.5
7	VL2B	77.5	897.5	33	TIMEOUT	1602.5	782.5
8	CUP1	77.5	782.5	34	SENSOR	1602.5	897.5
9	CUP2	77.5	667.5	35	P1	1602.5	1012.5
10	COM1	77.5	552.5	36	N.C.	1602.5	1127.5
11	COM2	77.5	437.5	37	C/F	1602.5	1242.5
12	COM3	77.5	322.5	38	CAP	1602.5	1357.5
13	N.C.	77.5	207.5	39	RDIS	1602.5	1472.5
14	N.C.	77.5	77.5	40	RRES	1602.5	1602.5
15	SEG1	207.5	77.5	41	RTH	1472.5	1602.5
16	SEG2	322.5	77.5	42	N.C.	1372.5	1602.5
17	SEG3	437.5	77.5	43	N.C.	1242.5	1602.5
18	SEG4	552.5	77.5	44	BZB	1127.5	1602.5
19	SEG5	667.5	77.5	45	BZ	1012.5	1602.5
20	SEG6	782.5	77.5	46	PSW	897.5	1602.5
21	SEG7	897.5	77.5	47	OPTR1	782.5	1602.5
22	SEG8	1012.5	77.5	48	OPTR2	667.5	1602.5
23	SEG9	1127.5	77.5	49	OPTR3	552.5	1602.5
24	SEG10	1242.5	77.5	50	RESET	437.5	1602.5
25	SEG11	1357.5	77.5	51	N.C.	322.5	1602.5
26	SEG12	1472.5	77.5	52	N.C.	207.5	1602.5

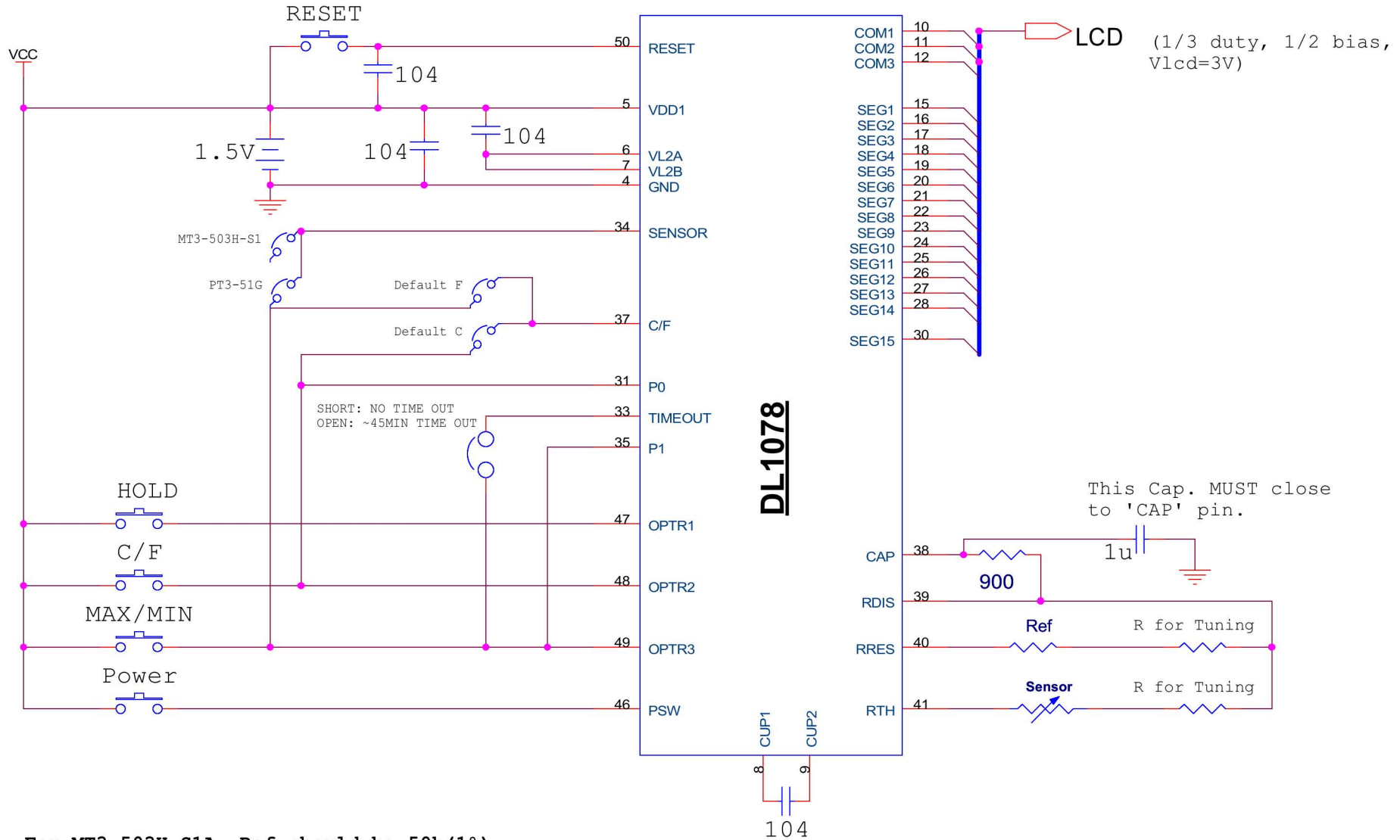

For MT3-503H-S1A, Ref should be 50k(1%)  
 For PT3-51G, Ref should be 47k(1%)

热敏电阻用100K 1% B值是3950的

Title		
DL1078		
Size	Document Number	Rev
		1.
Date:	Monday, January 31, 2011	Sheet 1 of 1
	2	1

# DL1078

宽温度IC



1/3 duty, 1/2 bias, 3Vlcd

